

Item Number	Document Number	Title	Quantity	Item Number	Document Number	Title	Quantity
1	10128	3/8" MED. SPLT L/W, T304 GR 5	4	40	18498	TOP COVER - FT40	1
2	10133	3/8-16 X 1" HEX BOLT. T304SS GR5	4	41	18500	END RING- FT 40	2
3	10976	3/8-16 SS HEX NUT	4	42	18502	CENTER BAFFLE - FT 40	1
4	1248	SPACER-1/4 x 1/2 (BAFFLE PLATE)	2	43	18503	SIDE BAFFLE - FT 40	1
5	13592	CASTER-TOTAL LOCKING-SWIVEL	2	44	18504	SCRAP CHUTE WELDMENT - FT40 / FT23	1
6	13593	CASTER-RIGID	2	45	18505	DISCHARGE SUPPORT - FT40 / FT23	1
7	13999-126	PULLEY, 1G-3.9"PD-0.625" BORE (60HZ)	1	46	18506	DISCHARGE COVER - FT 40 / FT23	1
8	15461	ELEMENTS-3000W/208V	3	47	18507	SCRAP SHIELD - FT23 / FT40	1
9	16602	CONTROL PANEL FRONT	1	48	18511	DOOR SEAL STRIP - ORIGINATE - AIR	1
10	17239	SCRAP BIN-FT80	1	49	18565	PELLET SHIELD	1
11	18275	BLOWER SHAFT	1	50	18577	PULLEY, 3.4"PD-0.75" BORE	1
12	18276-12	BLOWER WHEEL	1	51	18587	GUSSET SUPPORT-IIIN	1
13	18277	BLOWER INLET CONE	1	52	18594	MOTOR MOUNTING FRAME - FT40 / ORIGINATAIR	1
14	18279	HEAT SLINGER/SHAFT COOLER	2	53	18595	DRUM MOTOR CONDUIT	1
15	18280	FLANGE BEARING-3/4"	2	54	18612	DOOR SWITCH LEVER	1
16	18283-1	DRUM MOTOR MOUNT - FT40 / ORIGINATE AIR	1	55	18613	FEED HOPPER ASSY - IN-LINE- FT40 / ORIGINATE AIR	1
17	18286	DISCHARGE CHUTE-FT40	1	56	18617	FEED SUPPORT-FT-40	1
18	18288	GUSSET SUPPORT	1	57	18618	HOPPER SUPPORT - IN-LINE FEED	1
19	18289-ASSY	DOOR ASSEMBLY	1	58	18619-L	HOPPER SIDE SHIELD-LEFT	1
20	18294-CW	MOTOR - CLOCKWISE	2	59	18619-R	HOPPER SIDE SHIELD-RIGHT	1
21	18295	ELEMENT COVER - FT40 / ORIGINATE AIR	1	60	18622	CHAIN GUARD - IN-LINE FEED	1
22	18311	HINGE BLOCK	2	61	18623	PLATE - INLET - IN-LINE FEED	1
23	18312	ELEMENT BRACKET	1	62	18704	AUGER-FT40	1
24	18313	SHAFT GUARD - FT 40 / ORIGINATE AIR	1	63	18715	ENDCAP-AUGER SHAFT-FT40	1
25	18315	BELT GUARD - FT 40 / ORIGINATE AIR	1	64	18839	COVER-DISCHARGE CHUTE	1
26	18317	BELT-BLOWER-FT-40	1	65	3070	THERMOCOUPLE	2
27	18319-1	CHAIN GUARD COVER - FT40	1	66	3094	BIN LEVEL SWITCH	1
28	18322	1" x 2-1/2"LG S.S. PIPE NIPPLE-T.BE	2	67	3140-NP	PILLOW BLOCK - NICKEL - 1" BORE	2
29	18323	CONTROL BOX SUPPORT - FT40 / ORIGINATE AIR	2	68	3176-FM	MTR-1/3 HP 100-120/200-240V 50/60 HZ 1725/1425 RPM C-FACE-FOOT MOUNT	1
30	18328	CONDUIT NUT	4	69	3572	FEED CHUTE-80 PUFFER	1
31	18446	ELEMENT SUPPORT BRACKET - FT40	1	70	OR-Q1	CONTROL BOX	1
32	18480	DOOR CATCH SHIM - FT40	1				
33	18491	TANK BODY-FT40	1				
34	18492	FEED END COVER	1				
35	18493	DISCHARGE END PANEL - FT40	1				
36	18494	SIDE PANEL - OPERATOR SIDE - FT40	1				
37	18495	SIDE PANEL - FT40	1				
38	18496	SUB FRAME - FT40	1				
39	18497	BOTTOM PANEL - FT 40	1				

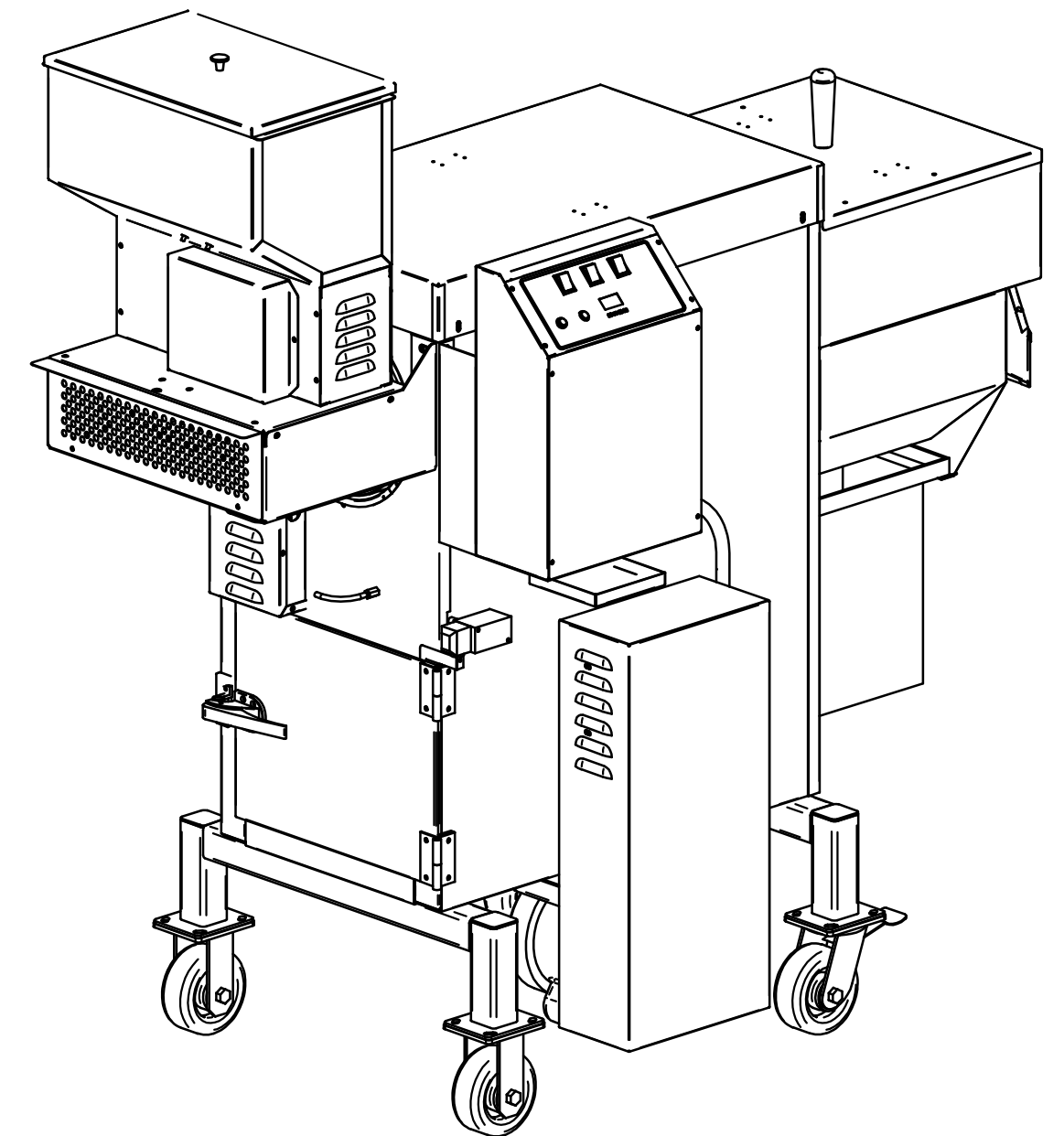

REV.	DESCRIPTION OF REVISION	BY	DATE

C. CRETORS & COMPANY
3243 N. CALIFORNIA AVE., CHICAGO, IL 60618-5890
TEL: 773/588-1690 FAX: 773/588-2171

This drawing contains information proprietary to C. Cretors & Co. and is furnished in confidence for the sole purposes of supplying the recipient with needed engineering data. Its contents should not be disclosed or reproduced in any manner without the written consent of C. Cretors & Co. All Rights Reserved.

TOLERANCES
X.XX = ±0.020
X.XXX = ±0.005
FRACT. = ±1/64
125 SURFACE FINISH
±5°
ALL HOLES +0.05
-0.000

NAME: FT40 POPPER - IN-LINE			
DRAWN BY: CAB	MATERIAL:		
DATE:	DATE:	SCALE:	DWG. No.
APPROVED:	DATE:	REV:	FT40 POPPER - IN-LINE