

BEGINNING SERIAL NO: 1905

REVISIONS			
REV	DC #	APPROVED BY	APPROVED ON
-	-	-	-
-	-	-	-
D	20017	nvidojevic	02/07/2020

BILL OF MATERIALS

ITEM #	Default/ QTY.	P/N	DESCRIPTION
1	1	19879	CORNDITIONER BOX, M5, HIGH OUTPUT
2	2	1656	THERMOSTAT, 180 DEG F
3	8	7642	#8-32 X 3/8"LG FULLY THD, PHIL TRUSS HEAD MACHINE SCREW, 18-8 S.S.
4	2	4858-E	HEAT ELEMENT, 400W, 240V, 144 OHMS
5	1	14712	CLIP, DUPLEX, 1/4"
6	5	14646	#8-32, KEPS NUT, STEEL NICKEL
7	1	19845-E	BLOWER, CROSSFLOW, 208, 240V
8	1	19887	COVER, CORNDITIONER BOX, M5
9	1	7803	#6-32 X 3/8"LG PHIL PAN HEAD T.C.S. TYPE "1" STEEL NICKEL
10	1	14986	WIRE HARNESS, DIPLOMAT CORNDITIONER

NOTE:

WIRING HARNESS (P/N: 14986) NOT SHOWN.
PLEASE REFER TO WIRING DIAGRAM.

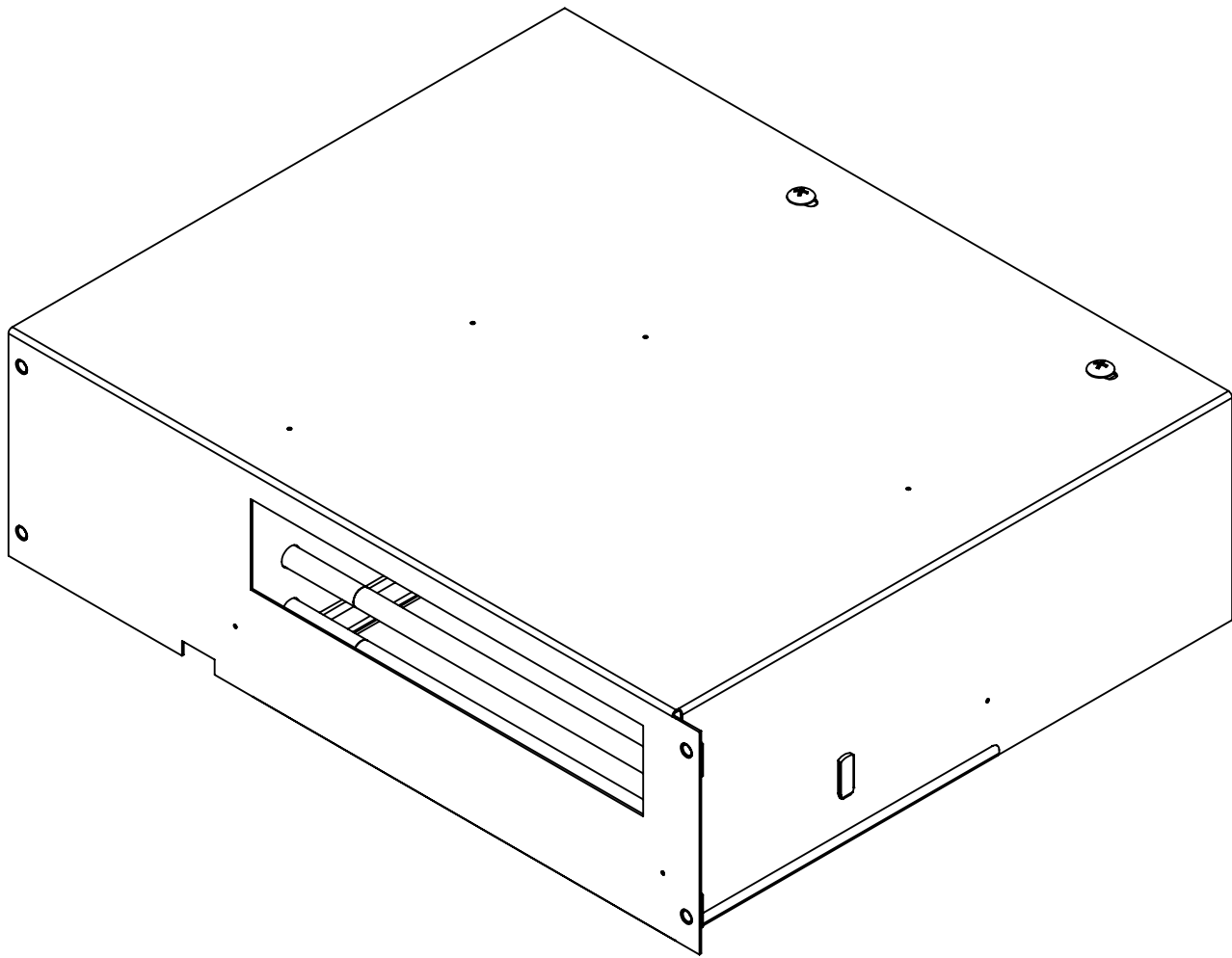

 176 MITTEL DRIVE, WOOD DALE, IL 60191 Ph:[847]616-6900, [800]228-1885, Fax:[847]616-6970 www.cretors.com, postmaster@cretors.com		DESCRIPTION	
DRAWN BY		CORNDITIONER, 230V, MACH 5	
kkedzior	DRAWN DATE	MATERIAL	APPROX. WEIGHT LBS
	02/06/2020	REFER INDIVIDUAL SUB-PARTS	1 OF 5
APPROVED BY	APPROVED DATE	DRAWING NUMBER	REVISION
nvidojevic	02/07/2020	14312-E	D

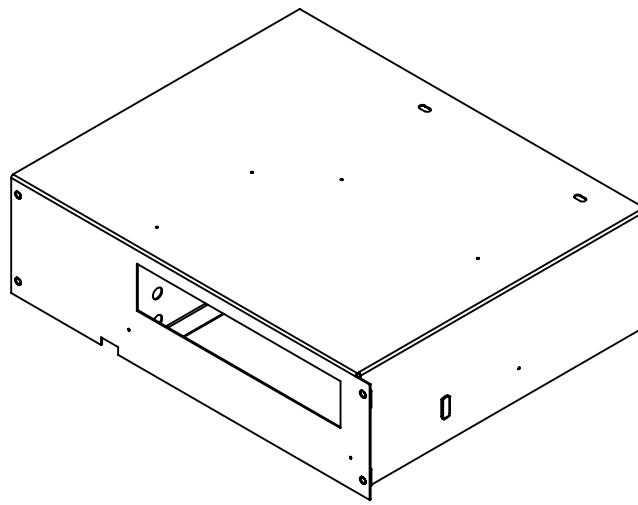

FLIP THE BOX OVER

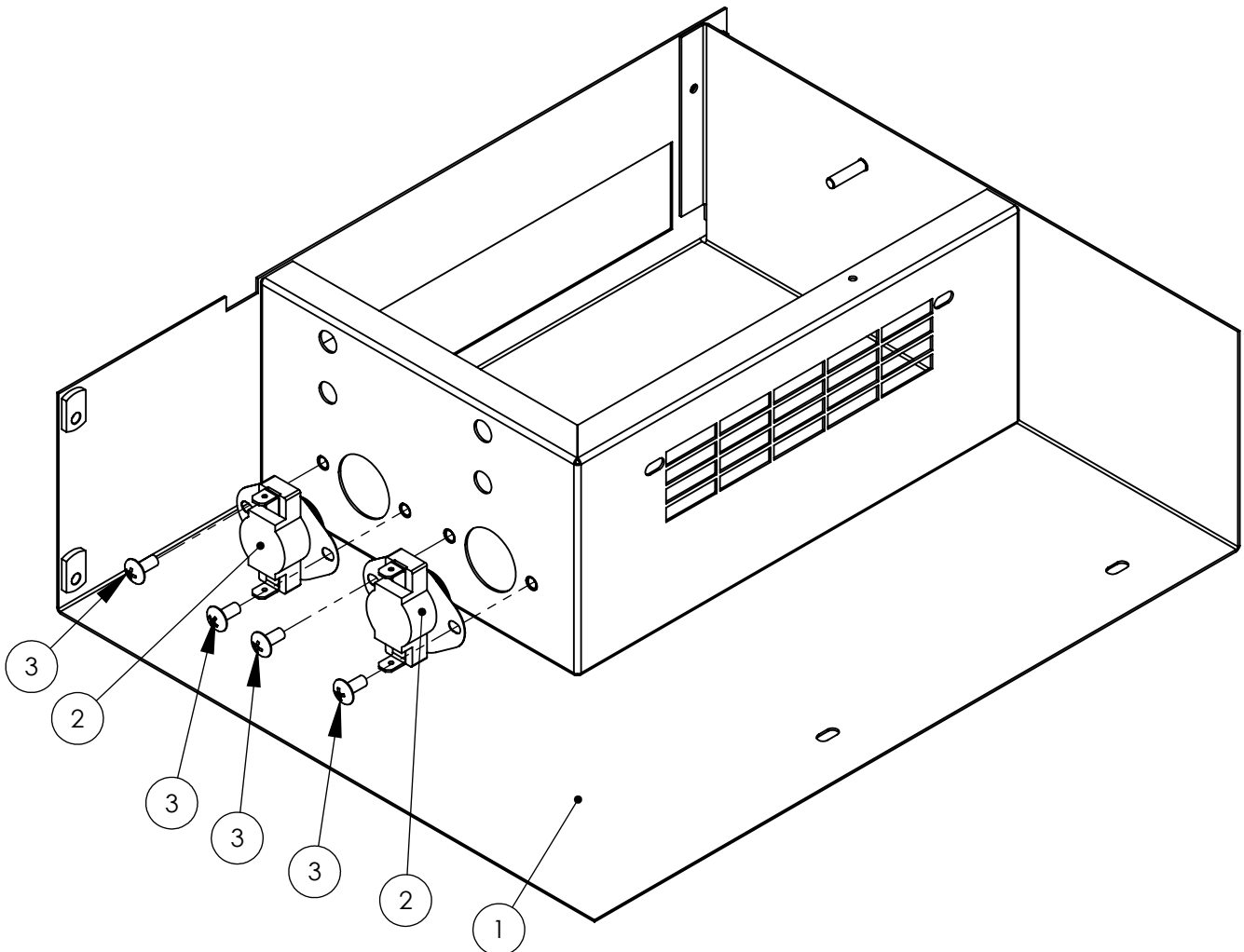

STEP # 1

 176 MITTEL DRIVE, WOOD DALE, IL 60191 Ph: (847) 616-6900, (800) 228-1885, Fax: (847) 616-6970 www.cretors.com, postmaster@cretors.com		DESCRIPTION	
		CORNDITIONER, 230V, MACH 5	
DRAWN BY	DRAWN DATE	MATERIAL	APPROX. WEIGHT LBS
kkedzior	02/06/2020	REFER INDIVIDUAL SUB-PARTS	271
APPROVED BY	APPROVED DATE	DRAWING NUMBER	SHEET 2 OF 5
nvidojevic	02/07/2020	14312-E	REVISION D

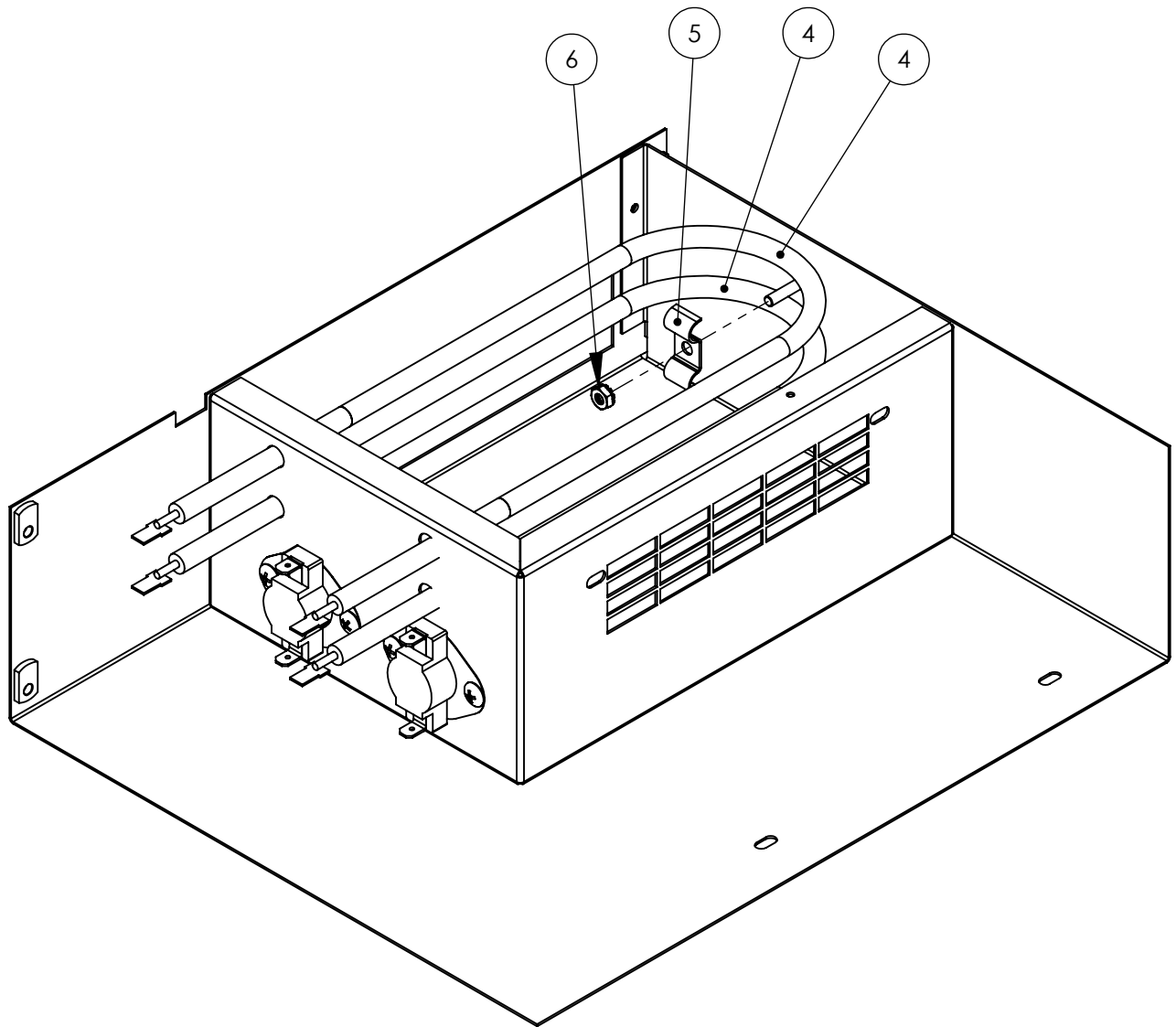

STEP # 2

176 MITTEL DRIVE, WOOD DALE, IL 60191 Ph: (847) 616-6900, (800) 228-1885, Fax: (847) 616-6970 www.cretors.com, postmaster@cretors.com		DESCRIPTION CORNDITIONER, 230V, MACH 5	
DRAWN BY	DRAWN DATE	MATERIAL	APPROX. WEIGHT LBS
kkedzior	02/06/2020	REFER INDIVIDUAL SUB-PARTS	3 OF 5
APPROVED BY	APPROVED DATE	DRAWING NUMBER	REVISION
nvidojevic	02/07/2020	14312-E	D

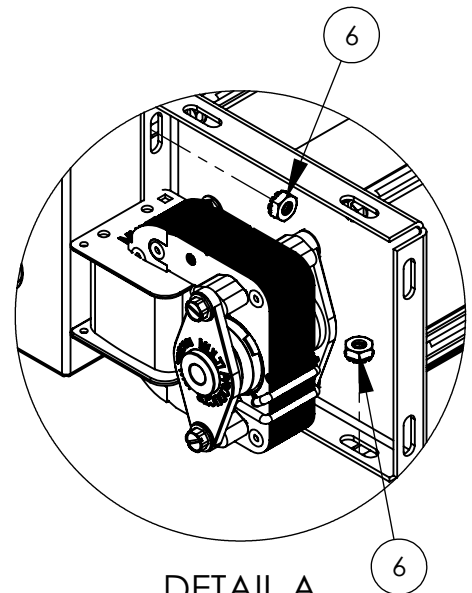
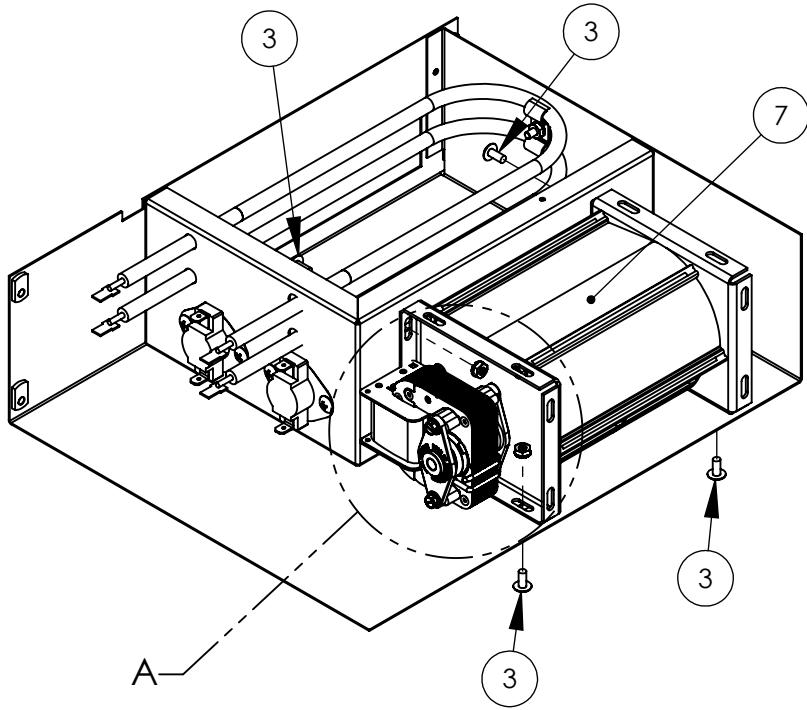

DETAIL A
SCALE 1 : 2.25

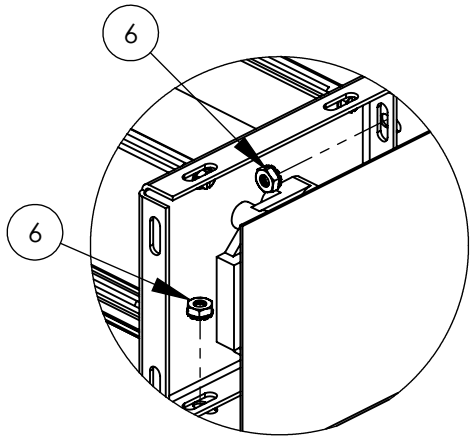

DETAIL B
SCALE 1 : 2.5

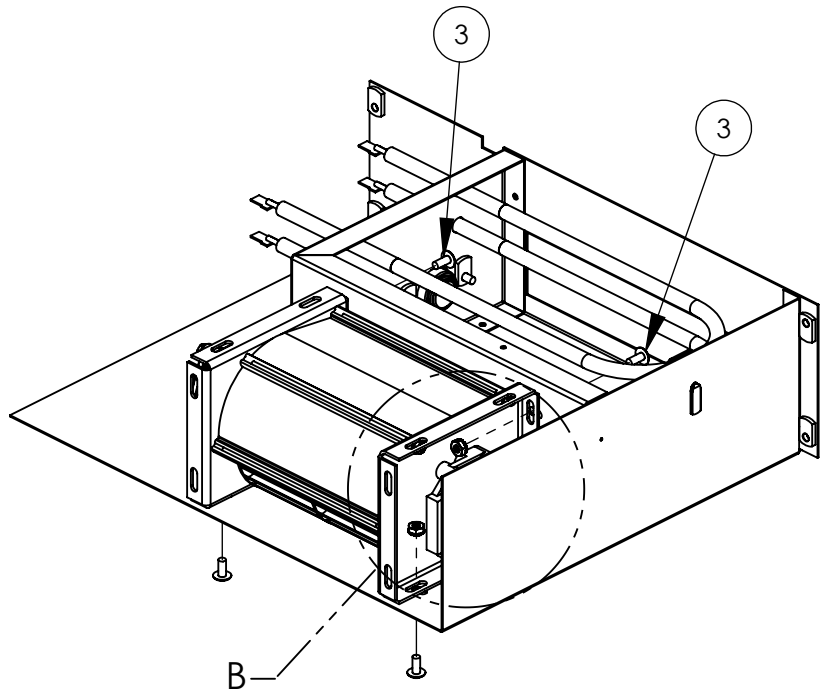

STEP # 3

 176 MITTEL DRIVE, WOOD DALE, IL 60191 Ph: (847) 616-6900, (800) 228-1885, Fax: (847) 616-6970 www.cretors.com, postmaster@cretors.com		DESCRIPTION	
DRAWN BY kkedzior		CORNDITIONER, 230V, MACH 5	
DRAWN DATE 02/06/2020		MATERIAL REFER INDIVIDUAL SUB-PARTS	
APPROVED BY nvidojevic		DRAWING NUMBER 14312-E	
APPROVED DATE 02/07/2020		APPROX. WEIGHT LBS 5.50	
		SHEET 4 OF 5	
		REVISION D	

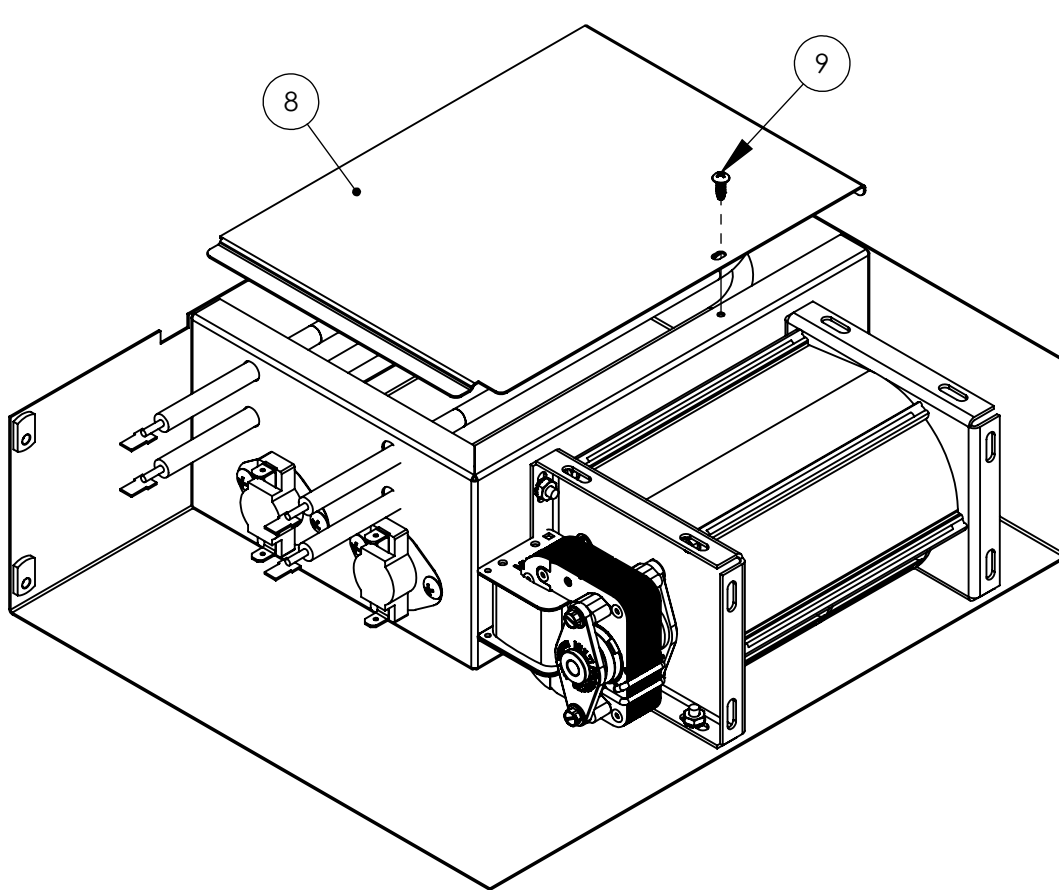

ASSEMBLE COVER
AS SHOWN

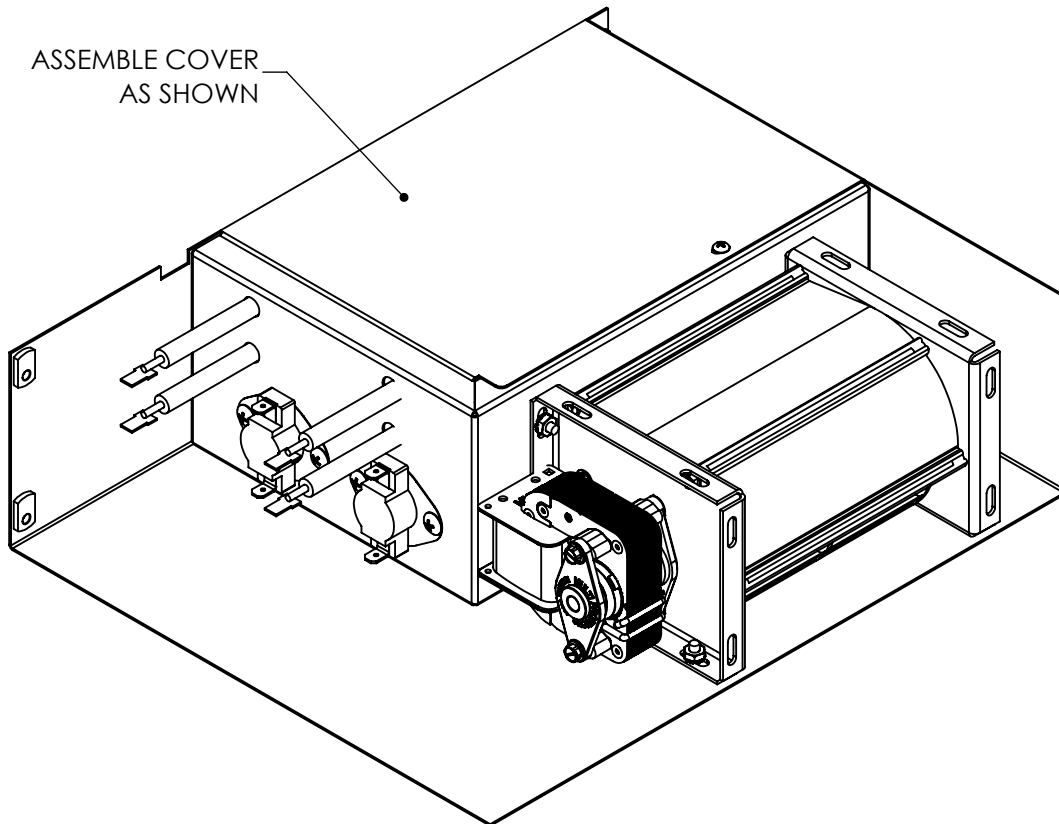

STEP # 4

 176 MITTEL DRIVE, WOOD DALE, IL 60191 Ph: (847) 616-6900, (800) 228-1885, Fax: (847) 616-6970 www.cretors.com, postmaster@cretors.com		DESCRIPTION	
		CORNDITIONER, 230V, MACH 5	
DRAWN BY	DRAWN DATE	MATERIAL	APPROX. WEIGHT LBS
kkedzior	02/06/2020	REFER INDIVIDUAL SUB-PARTS	5 OF 5
APPROVED BY	APPROVED DATE	DRAWING NUMBER	REVISION
nvidojevic	02/07/2020	14312-E	D

DIP/M5/MA KETTLE SUPPORT COLUMN
20/32/48/60 OZ.

DOC: Di200022

DI-20/32-E/H-2.0-C
06/06

BEGINNING SERIAL: 0606

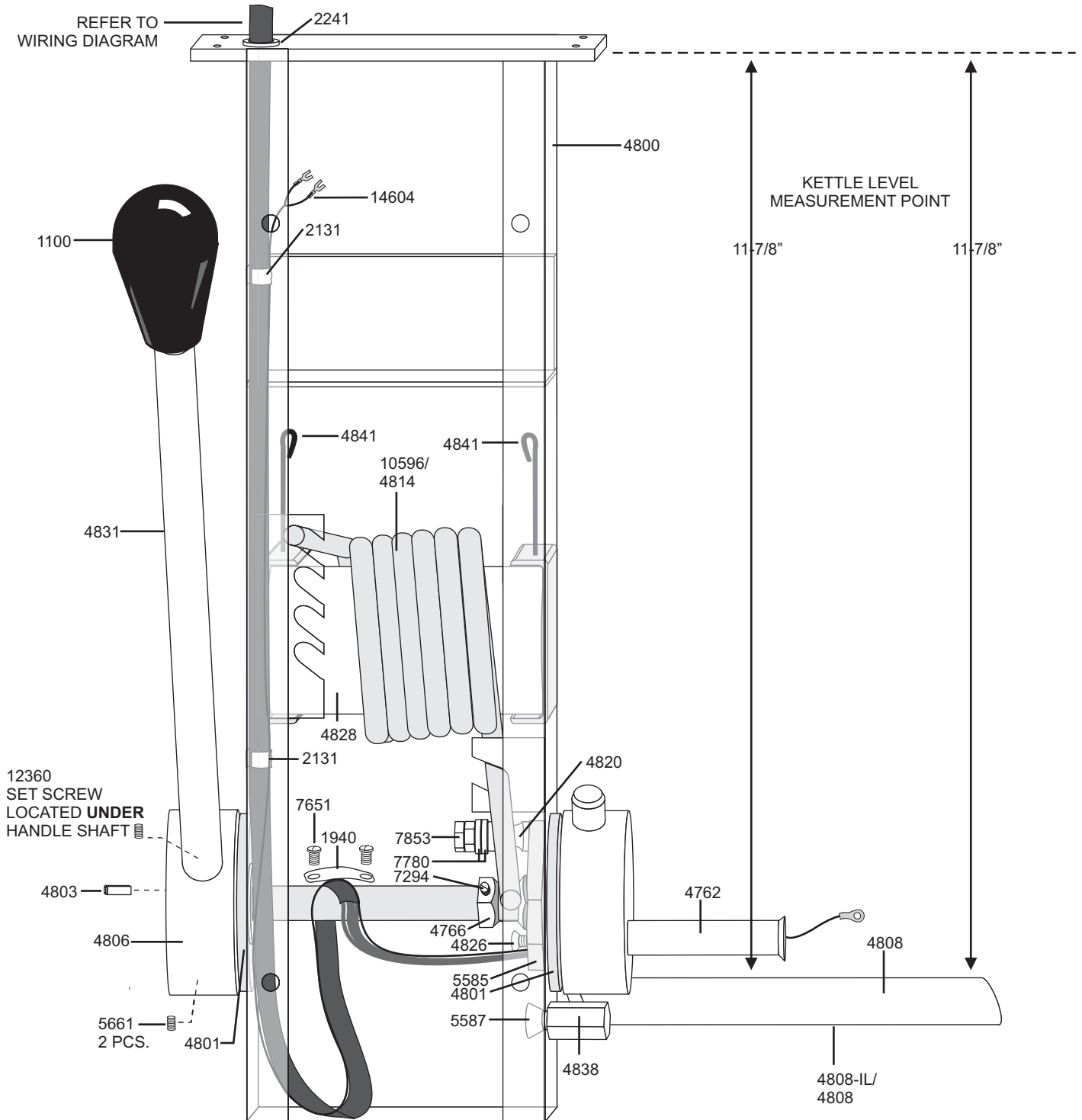

**DIP/M5/MA KETTLE SUPPORT COLUMN
20/32/48/60 OZ.**

DOC: Di200022

DI-20/32-E/H-2.0-C
06/06

BEGINNING SERIAL: 0606

1100	KNOB
1940	WIRE CLAMP FOR DIPLOMAT
2131	PIPE CLAMP #125
2241	1/2" INSULINER SLEEVE
4762	WIRE GUIDE TUBE
4766	KETTLE LEVEL NUT
4800	SUPPORT COLUMN - SPRING DUMP
4801	BEARING - COLUMN SUPPORT
4803	KEY - DIPLOMAT SPRING DUMP
4806	HANDLE HUB
4807	SUPPORT COLUMN COVER PLATE (NOT SHOWN)
4808	ECCENTRIC - DIP SPRING RETURN
4808-IL	ECCENTRIC - M5 SPRING RETURN
4814	RETURN SPRING (DI 20/32 OZ)
4820	ROLLER AND BEARING
4826	ARM BOLT 5/16-18 X 1
4828	SPRING HOLDER TUBE
4831	DUMP HANDLE - SPRING DUMP
4838	STOP BLOCK
4841	COTTER PIN 1/8 X 2
5585	SPRING ADJUSTMENT ARM
5587	3/8-16 X 3/4 FH SOCKET CAP
5661	5/16-18 X 1/2 SET SCREW
7294	10-32 X 3/16 SET SCREW, BRASS TIP
7651	10-24 X 1/2 B.H
7780	5/16 FLAT WASHER
7853	5/16-24 HEX NUT
10596	RETURN SPRING (DI48/60 OZ) M5 32/48/60
12360	1/2-20 X 3/8" SOCKET SET SCREW - UNDER 4831
14604	THERMOCOUPLE-RING TYPE-DIPLMAT

**48/60 OZ. MACH 5
KETTLE AND OPTIONAL SS KETTLE**

(Shown "Upside-Down")
Beginning Serial number 0910

M5200003

M5 48/60-C/D/E/G-2.0-B
10/09

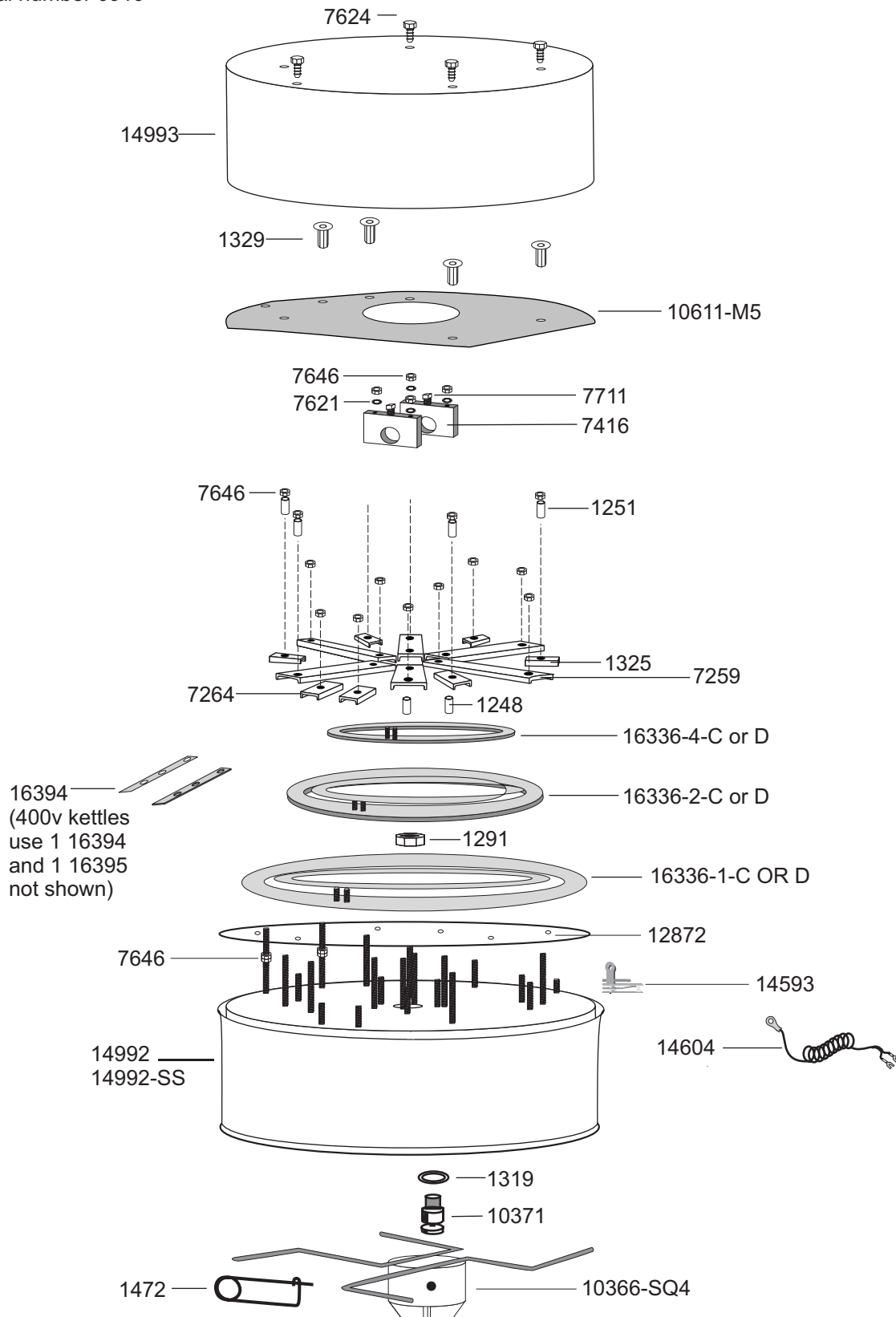

48/60 OZ. MACH 5
KETTLE AND OPTIONAL SS KETTLE

M5200003

M548/60-C/D/E/G-2.0-B
10/09

(Shown "Upside-Down") Beginning Serial No. 0910

1248	SPACER-1/4 x 1/2 (BAFFLE PLATE)
1251	5/8 " SPACER
1291	CENTER STUD LOCKNUT
1319	PAN CENTER WASHER
1329	RETAINER HEX SPACER
1325	ELEMENT CLAMP 3-1/4" (5 used)
1472	STIRRER BLADE RETAINING SPRING
7259	ELEMENT CLAMP 5-1/4" (6 used)
7264	ELEMENT CLAMP 5-1/4" (2 used)
7416	PAN MOUNTING BLOCK
7621	1/4" INTERNAL TOOTH LOCKWASHER
7624	1/4-28 x 1/2" HEX CAP
7646	1/4-28 HEX NUT
7711	5/16-18 x 1/2" SQUARE HEAD SCREW
10366-SQ4	STIRRER BLADE ASSEMBLY
10371	PAN CENTER
10611-M5	BAFFLE PLATE
12872	DIFFUSER PLATE
14593	HIGH LIMIT (LIMIT CONTROL)
14604	THERMOCOUPLE - RING TYPE - DIP
14992	POPPER PAN WITH STUD ASSY
14992-SS	POPPER PAN WITH STUD ASSY-STAINLESS STEEL
14993	RETAINER
16336-1-C	2000 WATT, 240 VOLT ELEMENT
16336-1-D	2000 WATT, 208 VOLT ELEMENT
16336-2-C	3050 WATT, 240 VOLT ELEMENT
16336-2-D	3050 WATT, 208 VOLT ELEMENT
16336-4-C	750 WATT, 240 VOLT ELEMENT
16336-4-D	750 WATT, 208 VOLT ELEMENT
16394	NICKEL STRAP--M5
16395	KETTLE ELEMENT JUMPER - 400V ONLY

* STAINLESS STEEL OPTION PARTS

**32 OZ. MACH 5
KETTLE AND OPTIONAL SS KETTLE**

(Shown "Upside-Down")
Beginning Serial No. 0910

M5200004

M5 32-C/D/E/G-2.0-B
10/09

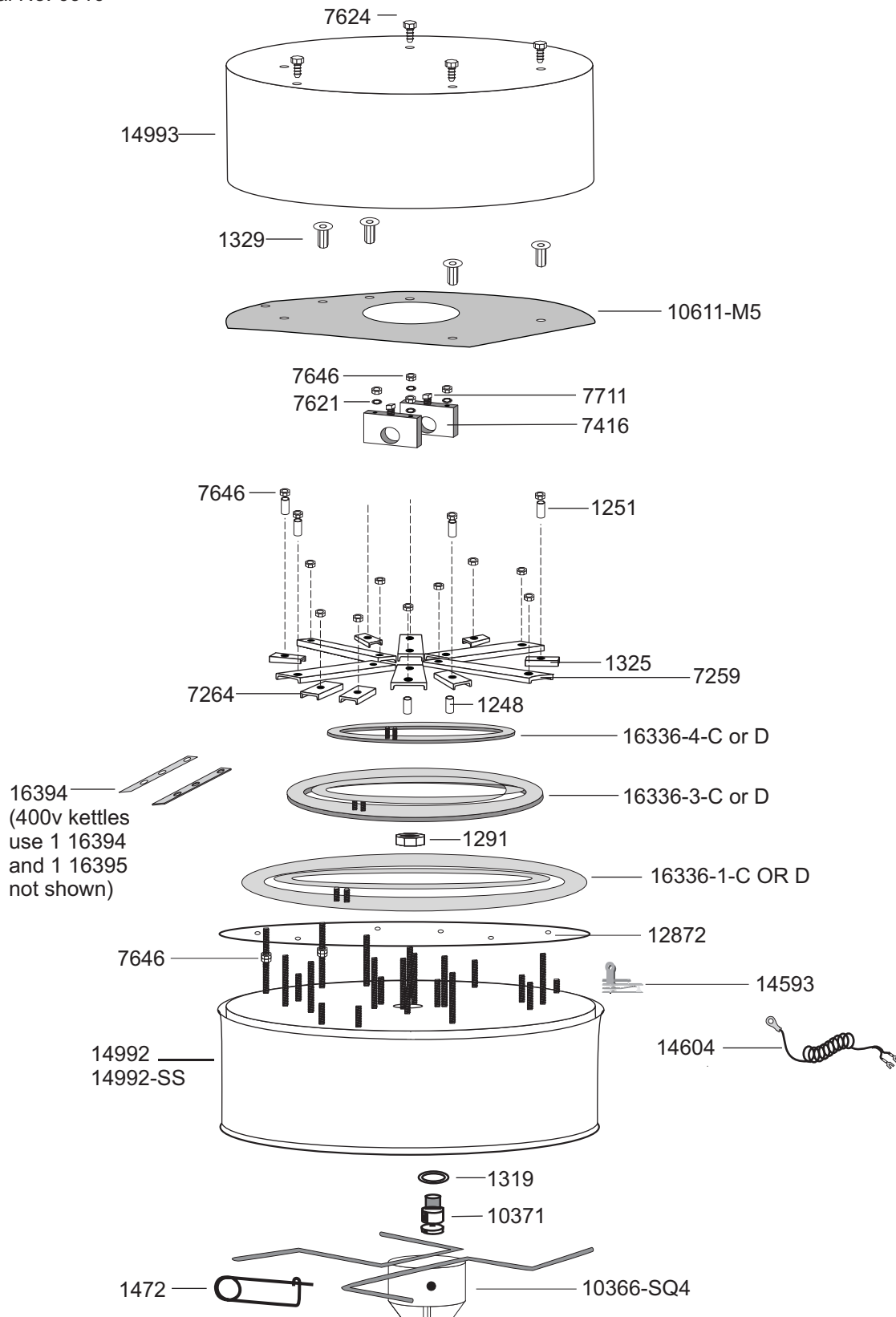

**32 OZ. MACH 5
KETTLE AND OPTIONAL SS KETTLE**

M5200004

M532-C/D/E/G-2.0-B
10/09

(Shown "Upside-Down") Beginning Serial No. 0910

1248	SPACER-1/4 x 1/2 (BAFFLE PLATE)
1251	5/8 " SPACER
1291	CENTER STUD LOCKNUT
1319	PAN CENTER WASHER
1329	RETAINER HEX SPACER
1325	ELEMENT CLAMP 3-1/4" (5 used)
1472	STIRRER BLADE RETAINING SPRING
7259	ELEMENT CLAMP 5-1/4" (6 used)
7264	ELEMENT CLAMP 5-1/4" (2 used)
7416	PAN MOUNTING BLOCK
7621	1/4" INTERNAL TOOTH LOCKWASHER
7624	1/4-28 x 1/2" HEX CAP
7646	1/4-28 HEX NUT
7711	5/16-18 x 1/2" SQUARE HEAD SCREW
10366-SQ4	STIRRER BLADE ASSEMBLY
10371	PAN CENTER
10611-M5	BAFFLE PLATE
12872	DIFFUSER PLATE
14593	HIGH LIMIT (LIMIT CONTROL)
14604	THERMOCOUPLE - RING TYPE - DIP
14992	POPPER PAN WITH STUD ASSY
14992-SS	POPPER PAN WITH STUD ASSY-STAINLESS STEEL
14993	RETAINER
16336-1-C	2000 WATT, 240 VOLT ELEMENT
16336-1-D	2000 WATT, 208 VOLT ELEMENT
16336-3-C	1500 WATT, 240 VOLT ELEMENT
16336-3-D	1500 WATT, 208 VOLT ELEMENT
16336-4-C	750 WATT, 240 VOLT ELEMENT
16336-4-D	750 WATT, 208 VOLT ELEMENT
16394	NICKEL STRAP--M5
16395	KETTLE ELEMENT JUMPER - 400V ONLY

* STAINLESS STEEL OPTION PARTS

MACH 5 32/48/60 OZ - BACK VIEW

BEGINNING SERIAL: 09030319

DOC: M5300001

M532/48/60-C/D/E/G-3.0-C

06/09

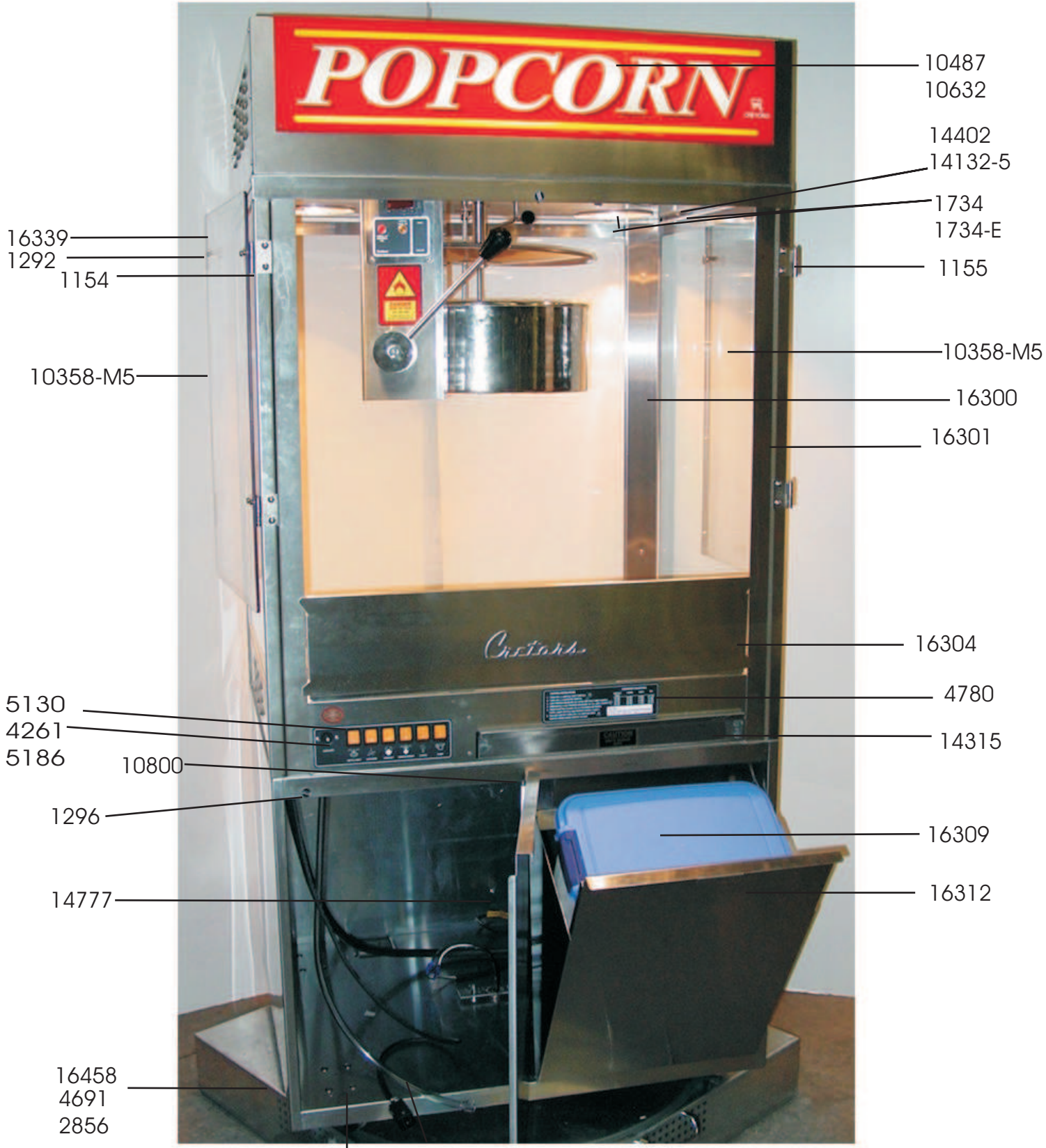

- 16339
- 1292
- 1154
- 10358-M5
- 5130
- 4261
- 5186
- 10800
- 1296
- 14777
- 16458
- 4691
- 2856
- 10487
- 10632
- 14402
- 14132-5
- 1734
- 1734-E
- 1155
- 10358-M5
- 16300
- 16301
- 16304
- 4780
- 14315
- 16309
- 16312

1223 2009-A/
2009-E

1154	DOOR HINGE & STRAP - LEFT(2)
1155	DOOR HINGE & STRAP - RIGHT(2)
1223	TUBING -NALGENE - CLEAR - PER FOOT
1292	KNOB
1296	MAGNETIC CATCH
1407	50 AMP RECEPTACLE(NOT SHOWN)
1734	LAMP-250W 120V.-IR HEAT LAMP
1734-E	LAMP-250W 230V.-IR HEAT LAMP
2009-A	PUMP CORD & PLUG - 120V
2009-E	PUMP CORD & PLUG - 230V (EXPORT)
2219	TRIM PROTECTIVE - POWER CABLE
2856	CORD 32 AMP (32/48/60 OZ 230V)
4261	CIRCUIT BREAKER(DOMESTIC ONLY)
4691	CORD 25 AMP - PER FOOT - 400V
4780	DECAL - INSTRUCTION 20/32/48/60 OZ
5130	ROCKER SWITCH
5186	DECAL-SWITCHPLATE
6012	DECAL - CAUTION-EMPTY DRAWER DAILY
10358-M5	PLEXI-DOOR LEFT AND RIGHT
10487	SIGN-POPCORN-RED & YELLOW
10632	SIGN BACKING
10800	SPRING
14118	POPPER CASE (NOT SHOWN)
14132-5	DISPOSABLE FILTER (PACK OF 5) NOT SHOWN
14402	FILTER HOUSING NOT SHOWN
14315	CLEAN OUT DRAWER
14777	DOOR - BASE
16300	INSIDE CORNER - FRONT
16301	INSIDE CORNER - REAR (NOT SHOWN)
16304	DROP SHELF
16309	CORN BIN
16312	CORN BIN SUPPORT
16458	CORD W/50 AMP PLUG

MACH 5 32/48/60 OZ.
MOTOR AND KETTLE ASSEMBLY
BEGINNING SERIAL: 1807

DOC: M5300002d

M5 C/D/E/G-2.0-C
07/18

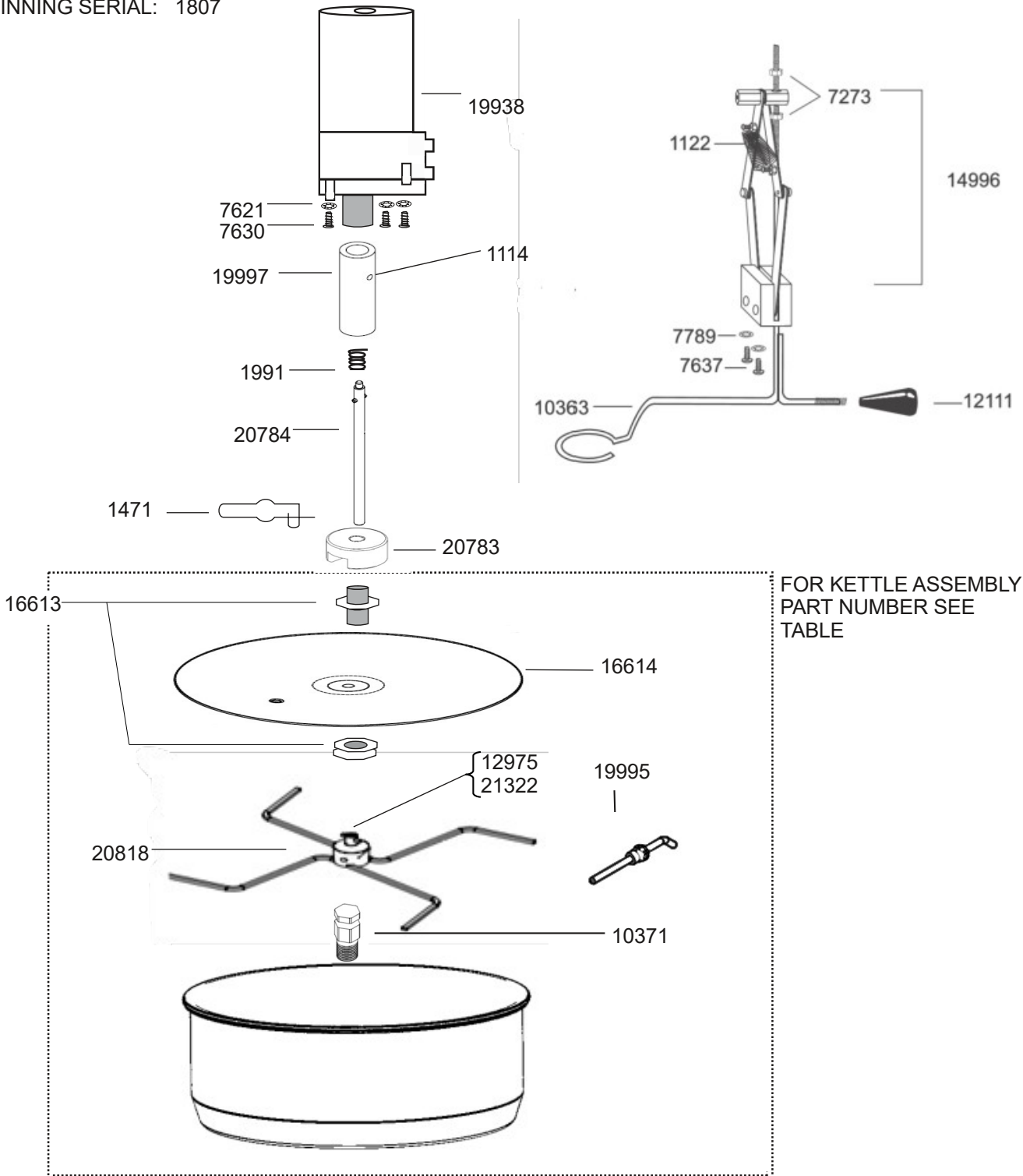

C. CRETORS AND COMPANY
176 MITTEL DRIVE
WOOD DALE, IL 60191
PHONE: (847)616-6900, (800)228-1885, FAX: (847) 616-6970
WEB SITE: [Http://www.cretor.com](http://www.cretor.com) Email: [postmaster @ cretors.com](mailto:postmaster@cretors.com)

Part Number	Description
1114	HEX CONNECTOR SET SCREW
1122	TRIP ARM SPRING
1471	COVER RETAINING SPRING
1991	SPRING
7273	1/4 x 20 HEX STOP NUT
7621	1/4" INTERNAL TOOTH LOCK-WASHER
7630	1/4 x 20 x 1/2" HEX BOLT
7637	8-32 x 1/2 SS TRUSS HEAD
7789	#8 STAR LOCK-WASHER
7865	10-32 ELASTIC STOP NUT
10363	COVER LIFT ROD
10371	PAN CENTER
12111	KNOB
12975	1/4-28 X 3/16 SET SCREW-CUP PT SOCKET
14996	AUTOMATIC COVER LIFT
16613	COVER CENTER & NUT-16 DIA PAN-7/8" HEX
16614	KETTLE COVER-DI 48/60 OZ.-9/16" HOLE
19938	MOTOR
19995	RETAINING PIN – STIRRER BLADE
19997	SHAFT CONNECTOR
20783	CLUTCH DOG, M5/DI 16" KETTLE
20784	DRIVE SHAFT, M5/DI 16" KETTLE
20818	STIRRER BLADE WELDMENT M5/DI 16" KETTLE
21322	DOWEL PIN, 3/16" x 1"LG, 18-8

Kettle Assembly	Description
21561-32-C	KETTLE, M5/DI, 16", 32 OZ, 240V
21561-32-C-SS	KETTLE, M5/DI, 16", SS, 32 OZ, 240V
21561-32-D	KETTLE, M5/DI, 16", 32 OZ, 208V
21561-32-D-30	KETTLE, M5, 16", 32 OZ, 208V, 30A
21561-32-D-SS	KETTLE, M5/DI, 16", SS, 32 OZ, 208V
21561-32-D-SS-30	KETTLE, M5, 16", SS, 32 OZ, 208V, 30A
21561-32-G	KETTLE, M5/DI, 16", 32 OZ, 400V
21561-32-G-SS	KETTLE, M5/DI, 16", SS, 32 OZ, 400V
21561-48-C	KETTLE, M5/DI, 16", 48 OZ, 240V
21561-48-D	KETTLE, M5/DI, 16", 48 OZ, 208V
21561-48-G	KETTLE, M5/DI, 16", 48 OZ, 400V
21561-60-C	KETTLE, M5/DI, 16", 60 OZ, 240V
21561-60-D	KETTLE, M5/DI, 16", 60 OZ, 208V
21561-60-G	KETTLE, M5/DI, 16", 60 OZ, 400V

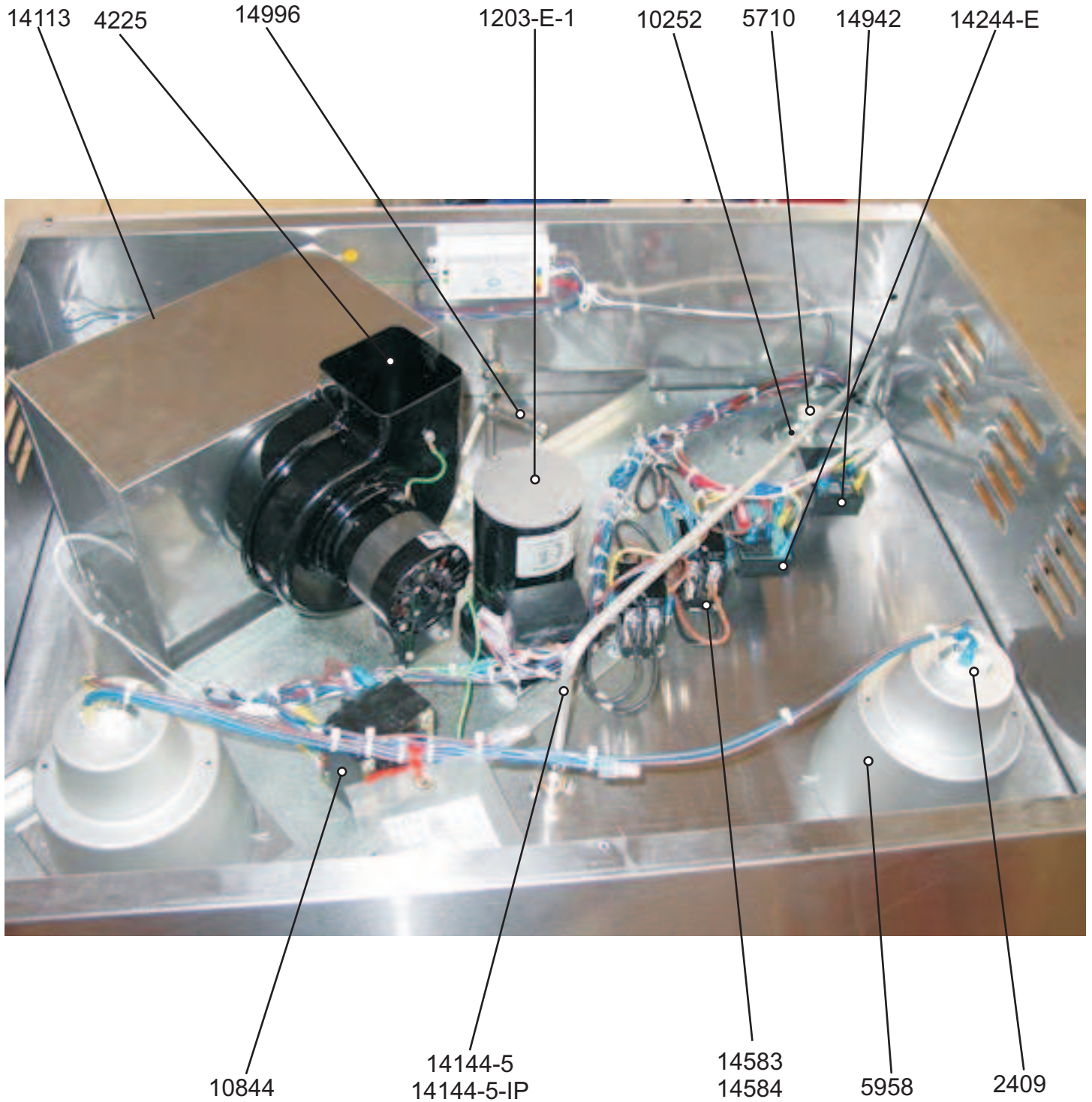

MACH 5 32/48/60 OZ - TOP VIEW

BEGINNING SERIAL: 0905

DOC: M5300006

M532/48/60-C/D/E/G-3.1-A

11/11

1203-E-1	AGITATOR MOTOR
2409	PORCELAIN SOCKET
4225	BLOWER-230V
5710	SOCKET-HALOGEN-QCX-34
5958	LAMP GUARD-SPUN (R40 BULB)
10252	LAMP-HALOGEN-Q50MR16C/CC55
10844	TRANSFORMER-100W/120V/230V-12V/24V,VDE
14113	FILTER BOX-MR32
14144-5	RISER TUBE-MACH 5
14144-5-IP	RISER TUBE-MACH 5-INTEGRATED PUMP
14244-E	TIMER/RELAY-1 POP-230V (ONLY USED ON ONE-POP AND SALT/SUGAR MODELS)
14583	RELAY-230V-SINGLE POLE
14584	RELAY-230V-DOUBLE POLE
14942	HIGH LIMIT/LATCHING RELAY-CE (ONLY USED ON 400V MODELS)
14996	AUTOMATIC COVER LIFT

NOTE: NOT ALL ITEMS ARE ON ALL MACHINES

C. CRETORS AND COMPANY

176 MITTEL DRIVE

WOOD DALE, IL 60191

PHONE: (847)616-6900, (800)228-1885, FAX: (847) 616-6970

WEB SITE: <http://www.cretors.com> Email: postmaster@cretors.com

MACH 5 & DIPLOMAT 48/60 OZ

AGITATOR DRIVE SYSTEM

BEGINNING SERIAL: 1807

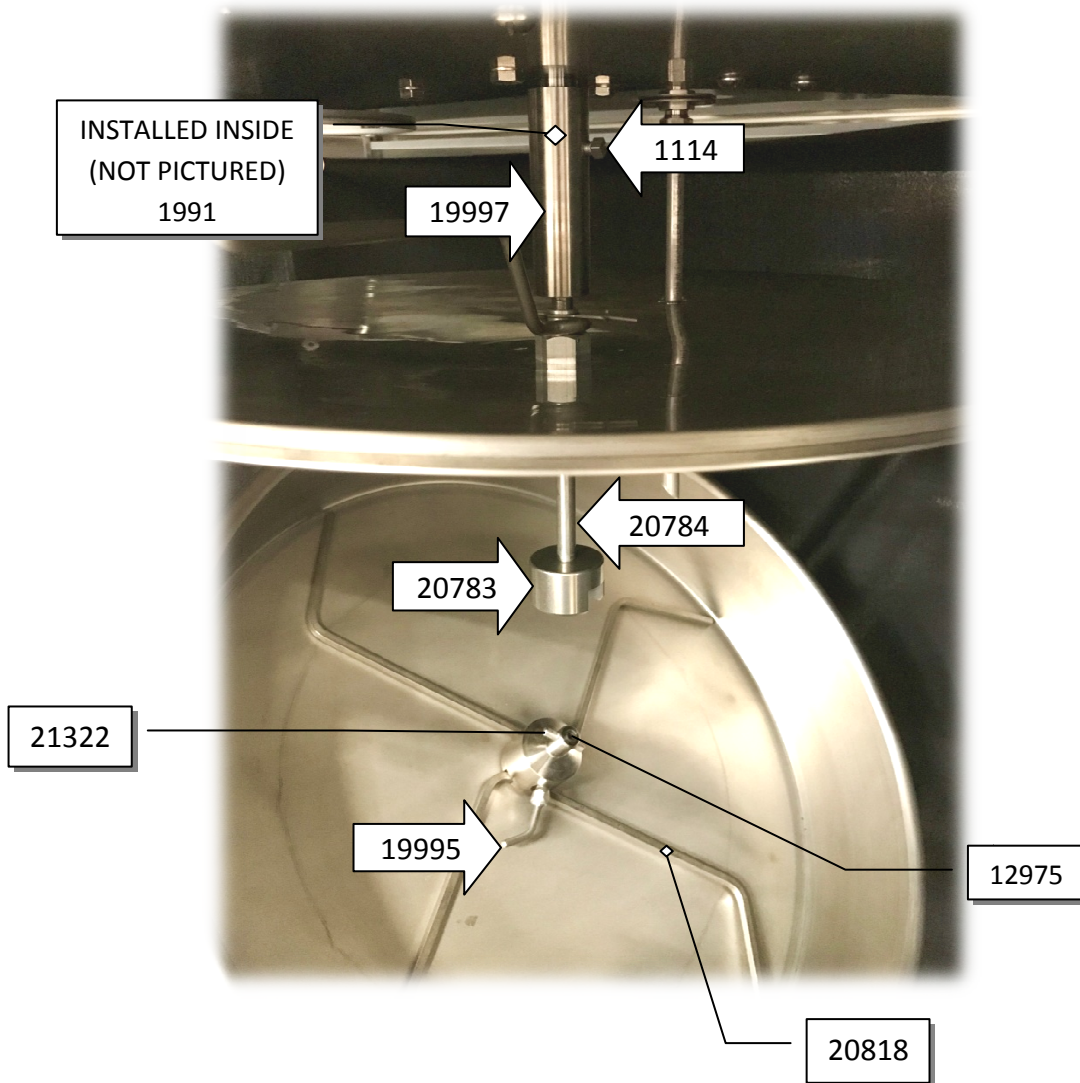

PART NUMBER	DESCRIPTION	QUANTITY
1991	SPRING, 0.125" PITCH, 0.036" WIRE DIAMETER	1
1114	1/4-20 X 3/8"LG, SQ HD SET SCREW, CUP POINT, 18-8 S.S.	1
19997	SHAFT CONNECTOR	1
20784	DRIVE SHAFT, M5/DI, 16" KETTLE	1
20783	CLUTCH DOG, M5/DI, 16" KETTLE	1
21322	3/16"DIA X 1"LG, GROOVED PIN, 18-8 S.S.	1
12975	1/4-28 X 3/16"LG, SOCKET SET SCREW, CUP POINT, ALLOY PLAIN	1
20818	STIRRER BLADE WELDMENT, M5/DI, 16" KETTLE	1
19995	RETAINING PIN, STIRRER BLADE	1

C. CRETORS AND COMPANY
 176 MITTEL DRIVE
 WOOD DALE, IL 60191
 PHONE: (847) 616-6900, (800) 228-1885
 FAX: (847) 616-6970
 WEBSITE: WWW.CRETORS.COM
 EMAIL: POSTMASTER@CRETORS.COM