

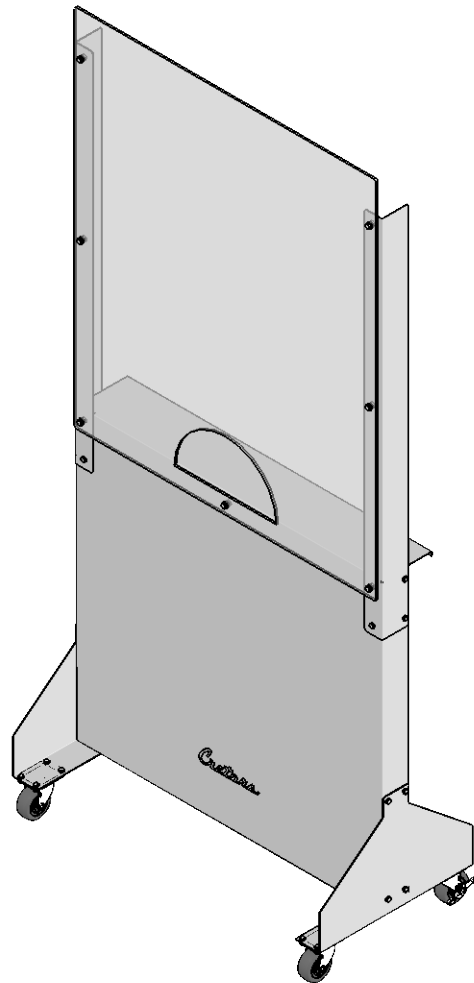

REVISIONS

REV	DC #	APPROVED BY	APPROVED ON
-	-	-	-
-	-	-	-
P1	-	ndarji	06/02/2020

BILL OF MATERIALS

ITEM #	QTY.	P/N	DESCRIPTION
1	1	22744	STEEL PANEL, FLOOR SHIELD, STANDARD
2	1	22657	FRAME, RIGHT, FLOOR SHIELD
3	1	22658	FRAME, LEFT, FLOOR SHIELD
4	1	22660	CLEAR PANEL, FLOOR SHIELD
5	2	22661	BASE, FLOOR SHIELD
6	2	12085	SWIVEL CASTER W/ BRAKE 3 X 1-1/4
7	2	12086	SWIVEL CASTER 3 X 1-1/4 PLATE
8	7	22655	SPACER, NYLON, 25" ID X .1875" THK
9	32	10121	1/4-20 X 1/2" LG FULLY THD, HEX HEAD CAP SCREW, 18-8 S.S.
10	7	7615	1/4-20 X 3/4" LG FULLY THD, HEX HEAD CAP SCREW, 18-8 S.S.
11	7	5742	1/4", SAE FLAT WASHER, 18-8 S.S.
12	39	22743	1/4-20, NYLON INSERT LOCKNUT, NICKEL PL
13	1	22718	DECAL, CRETORS CONTACT INFO



 176 MITTEL DRIVE, WOOD DALE, IL 60191 Ph: (847) 616-6900, (800) 228-1885, Fax: (847) 616-6970 www.cretors.com, postmaster@cretors.com		DESCRIPTION	
		FLOOR SHIELD, ASSEMBLY, STANDARD	
DRAWN BY	DRAWN DATE	MATERIAL	APPROX. WEIGHT LBS
pwozny	06/02/2020	REFER INDIVIDUAL SUB-PARTS	49.3
APPROVED BY	APPROVED DATE	DRAWING NUMBER	SHEET 1 OF 6
ndarji	06/02/2020	22656-STD	REVISION P1

BILL OF MATERIALS

ITEM #	QTY.	P/N	DESCRIPTION
1	1	22744	STEEL PANEL, FLOOR SHIELD, STANDARD
2	1	22657	FRAME, RIGHT, FLOOR SHIELD
3	1	22658	FRAME, LEFT, FLOOR SHIELD
4	1	22660	CLEAR PANEL, FLOOR SHIELD
5	2	22661	BASE, FLOOR SHIELD
6	2	12085	SWIVEL CASTER W/ BRAKE 3 X 1-1/4
7	2	12086	SWIVEL CASTER 3 X 1-1/4 PLATE
8	7	22655	SPACER, NYLON, 25" ID X .1875" THK
9	32	10121	1/4-20 X 1/2" LG FULLY THD, HEX HEAD CAP SCREW, 18-8 S.S.
10	7	7615	1/4-20 X 3/4" LG FULLY THD, HEX HEAD CAP SCREW, 18-8 S.S.
11	7	5742	1/4", SAE FLAT WASHER, 18-8 S.S.
12	39	22743	1/4-20, NYLON INSERT LOCKNUT, NICKEL PL
13	1	22718	DECAL, CRETORS CONTACT INFO

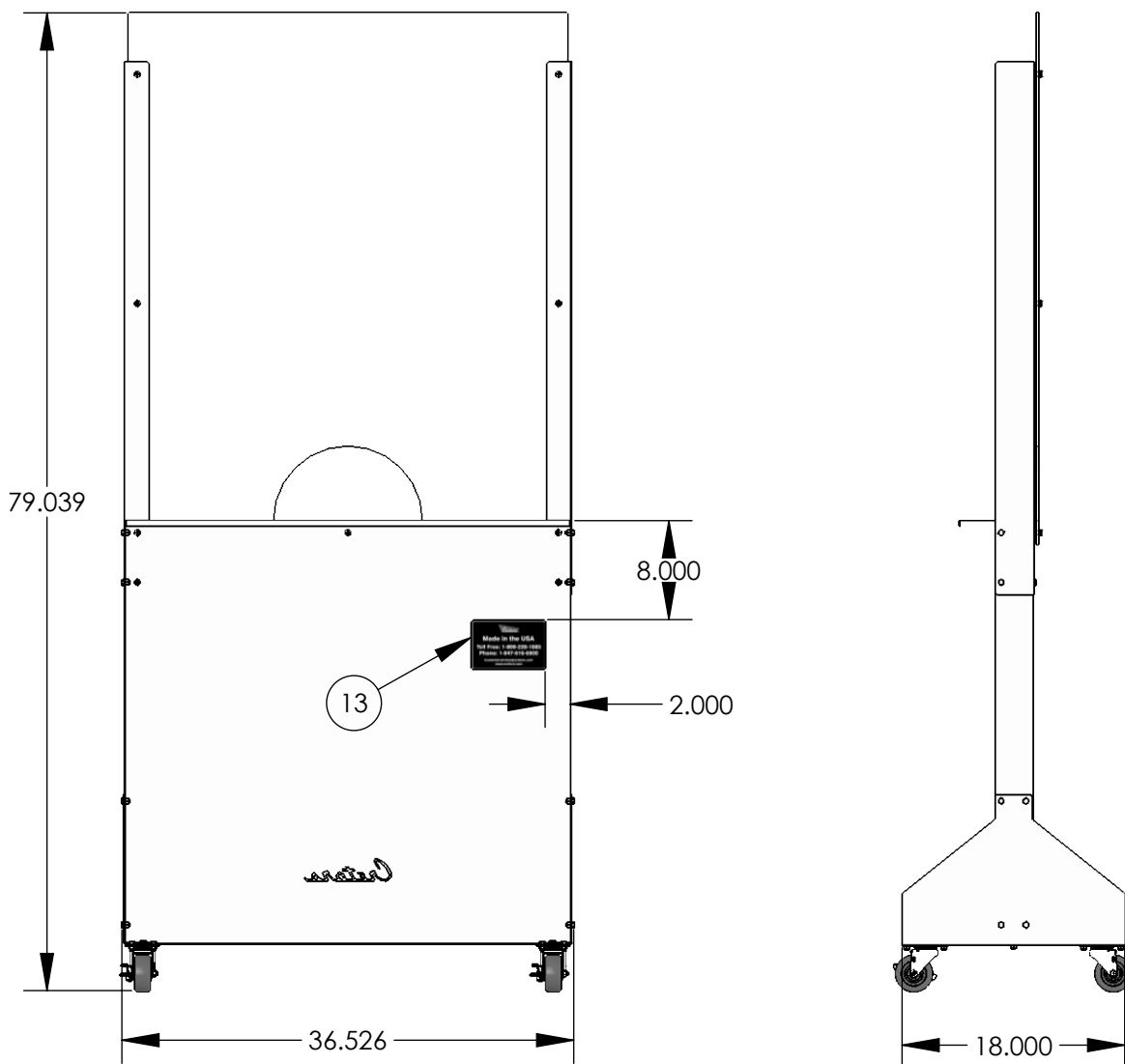

 176 MITTEL DRIVE, WOOD DALE, IL 60191 Ph: (847) 616-6900, (800) 228-1885, Fax: (847) 616-6970 www.cretors.com, postmaster@cretors.com		DESCRIPTION FLOOR SHIELD, ASSEMBLY, STANDARD	
DRAWN BY pwozny	DRAWN DATE 06/02/2020	MATERIAL REFER INDIVIDUAL SUB-PARTS	APPROX. WEIGHT 49.3 LBS
APPROVED BY ndarji	APPROVED DATE 06/02/2020	DRAWING NUMBER 22656-STD	SHEET 2 OF 6
			REVISION P1

BILL OF MATERIALS

ITEM #	QTY.	P/N	DESCRIPTION
1	1	22744	STEEL PANEL, FLOOR SHIELD, STANDARD
2	1	22657	FRAME, RIGHT, FLOOR SHIELD
3	1	22658	FRAME, LEFT, FLOOR SHIELD
4	1	22660	CLEAR PANEL, FLOOR SHIELD
5	2	22661	BASE, FLOOR SHIELD
6	2	12085	SWIVEL CASTER W/ BRAKE 3 X 1-1/4
7	2	12086	SWIVEL CASTER 3 X 1-1/4 PLATE
8	7	22655	SPACER, NYLON, 25" ID X .1875" THK
9	32	10121	1/4-20 X 1/2" LG FULLY THD, HEX HEAD CAP SCREW, 18-8 S.S.
10	7	7615	1/4-20 X 3/4" LG FULLY THD, HEX HEAD CAP SCREW, 18-8 S.S.
11	7	5742	1/4", SAE FLAT WASHER, 18-8 S.S.
12	39	22743	1/4-20, NYLON INSERT LOCKNUT, NICKEL PL
13	1	22718	DECAL, CRETORS CONTACT INFO

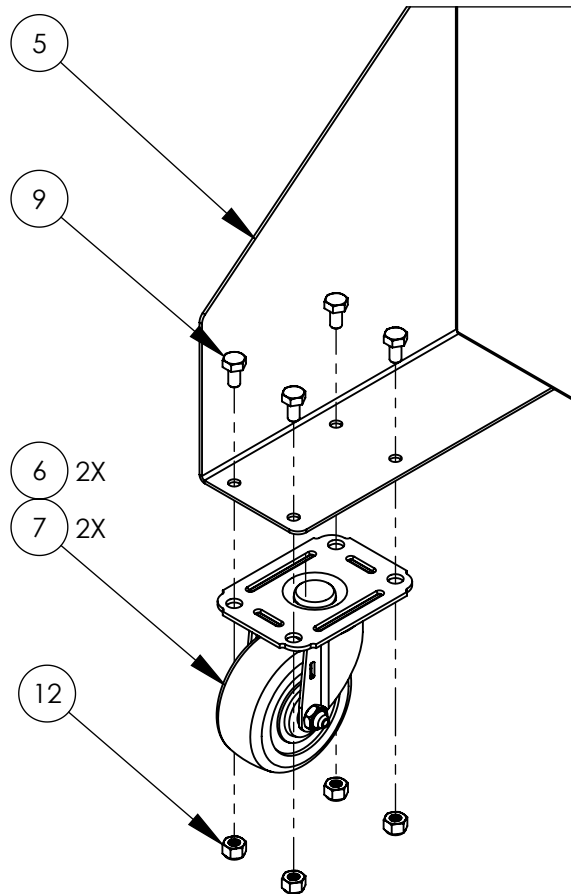

STEP # 1

 176 MITTEL DRIVE, WOOD DALE, IL 60191 Ph: (847) 616-6900, (800) 228-1885, Fax: (847) 616-6970 www.cretors.com, postmaster@cretors.com		DESCRIPTION FLOOR SHIELD, ASSEMBLY, STANDARD	
DRAWN BY pwozny	DRAWN DATE 06/02/2020	MATERIAL REFER INDIVIDUAL SUB-PARTS	APPROX. WEIGHT 49.3 LBS
APPROVED BY ndarji	APPROVED DATE 06/02/2020	DRAWING NUMBER 22656-STD	SHEET 3 OF 6 REVISION P1

BILL OF MATERIALS

ITEM #	QTY.	P/N	DESCRIPTION
1	1	22744	STEEL PANEL, FLOOR SHIELD, STANDARD
2	1	22657	FRAME, RIGHT, FLOOR SHIELD
3	1	22658	FRAME, LEFT, FLOOR SHIELD
4	1	22660	CLEAR PANEL, FLOOR SHIELD
5	2	22661	BASE, FLOOR SHIELD
6	2	12085	SWIVEL CASTER W/ BRAKE 3 X 1-1/4
7	2	12086	SWIVEL CASTER 3 X 1-1/4 PLATE
8	7	22655	SPACER, NYLON, 25" ID X .1875" THK
9	32	10121	1/4-20 X 1/2" LG FULLY THD, HEX HEAD CAP SCREW, 18-8 S.S.
10	7	7615	1/4-20 X 3/4" LG FULLY THD, HEX HEAD CAP SCREW, 18-8 S.S.
11	7	5742	1/4", SAE FLAT WASHER, 18-8 S.S.
12	39	22743	1/4-20, NYLON INSERT LOCKNUT, NICKEL PL
13	1	22718	DECAL, CRETORS CONTACT INFO

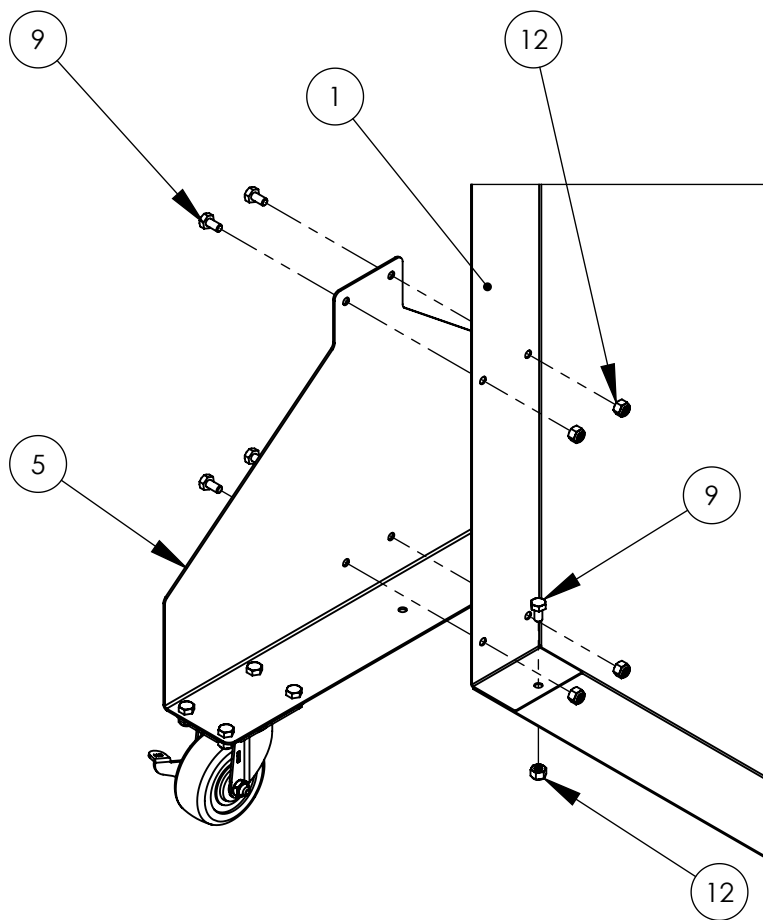

STEP # 2

 176 MITTEL DRIVE, WOOD DALE, IL 60191 Ph: (847) 616-6900, (800) 228-1885, Fax: (847) 616-6970 www.cretors.com, postmaster@cretors.com		DESCRIPTION FLOOR SHIELD, ASSEMBLY, STANDARD	
DRAWN BY pwozny	DRAWN DATE 06/02/2020	MATERIAL REFER INDIVIDUAL SUB-PARTS	APPROX. WEIGHT 49.3 LBS
APPROVED BY ndarji	APPROVED DATE 06/02/2020	DRAWING NUMBER 22656-STD	SHEET 4 OF 6 REVISION P1

BILL OF MATERIALS

ITEM #	QTY.	P/N	DESCRIPTION
1	1	22744	STEEL PANEL, FLOOR SHIELD, STANDARD
2	1	22657	FRAME, RIGHT, FLOOR SHIELD
3	1	22658	FRAME, LEFT, FLOOR SHIELD
4	1	22660	CLEAR PANEL, FLOOR SHIELD
5	2	22661	BASE, FLOOR SHIELD
6	2	12085	SWIVEL CASTER W/ BRAKE 3 X 1-1/4
7	2	12086	SWIVEL CASTER 3 X 1-1/4 PLATE
8	7	22655	SPACER, NYLON, 25" ID X .1875" THK
9	32	10121	1/4-20 X 1/2" LG FULLY THD, HEX HEAD CAP SCREW, 18-8 S.S.
10	7	7615	1/4-20 X 3/4" LG FULLY THD, HEX HEAD CAP SCREW, 18-8 S.S.
11	7	5742	1/4", SAE FLAT WASHER, 18-8 S.S.
12	39	22743	1/4-20, NYLON INSERT LOCKNUT, NICKEL PL
13	1	22718	DECAL, CRETORS CONTACT INFO

7 INSTANCES FOR PANEL

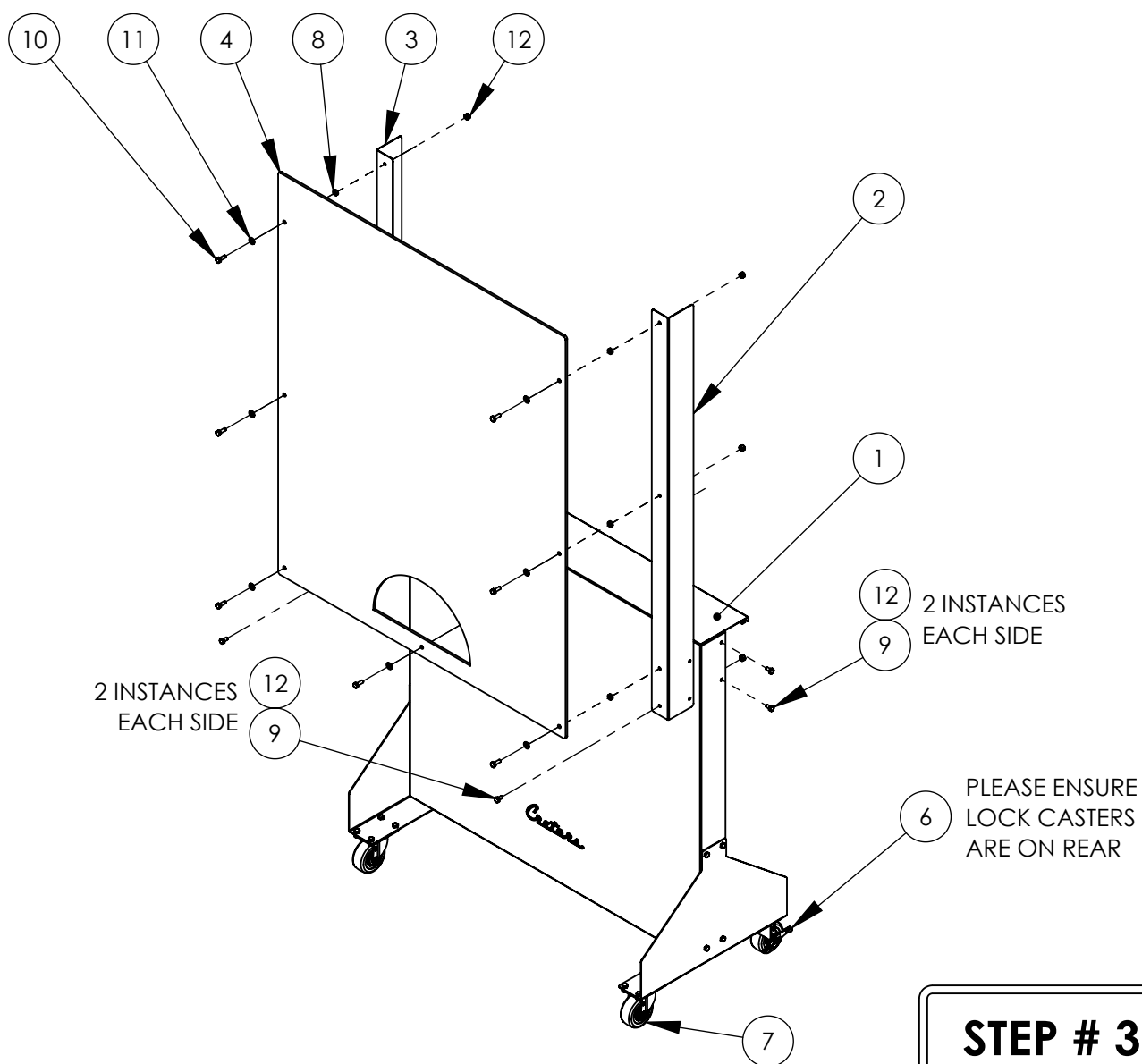

STEP # 3

 176 MITTEL DRIVE, WOOD DALE, IL 60191 Ph: (847) 616-6900, (800) 228-1885, Fax: (847) 616-6970 www.cretors.com, postmaster@cretors.com		DESCRIPTION FLOOR SHIELD, ASSEMBLY, STANDARD	
DRAWN BY pwozny	DRAWN DATE 06/02/2020	MATERIAL REFER INDIVIDUAL SUB-PARTS	APPROX. WEIGHT 49.3 LBS
APPROVED BY ndarji	APPROVED DATE 06/02/2020	DRAWING NUMBER 22656-STD	SHEET 5 OF 6 REVISION P1

BILL OF MATERIALS

ITEM #	QTY.	P/N	DESCRIPTION
1	1	22744	STEEL PANEL, FLOOR SHIELD, STANDARD
2	1	22657	FRAME, RIGHT, FLOOR SHIELD
3	1	22658	FRAME, LEFT, FLOOR SHIELD
4	1	22660	CLEAR PANEL, FLOOR SHIELD
5	2	22661	BASE, FLOOR SHIELD
6	2	12085	SWIVEL CASTER W/ BRAKE 3 X 1-1/4
7	2	12086	SWIVEL CASTER 3 X 1-1/4 PLATE
8	7	22655	SPACER, NYLON, 25" ID X .1875" THK
9	32	10121	1/4-20 X 1/2" LG FULLY THD, HEX HEAD CAP SCREW, 18-8 S.S.
10	7	7615	1/4-20 X 3/4" LG FULLY THD, HEX HEAD CAP SCREW, 18-8 S.S.
11	7	5742	1/4", SAE FLAT WASHER, 18-8 S.S.
12	39	22743	1/4-20, NYLON INSERT LOCKNUT, NICKEL PL
13	1	22718	DECAL, CRETORS CONTACT INFO

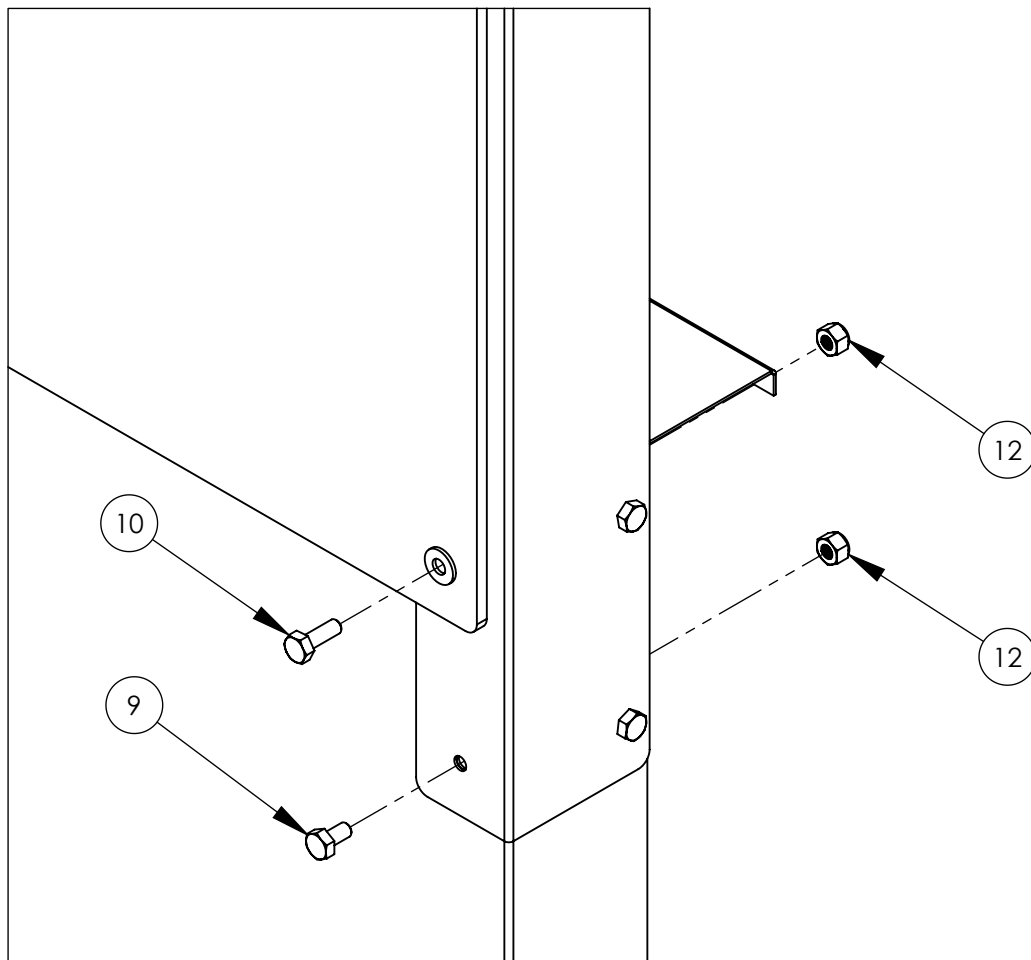

STEP # 3

 176 MITTEL DRIVE, WOOD DALE, IL 60191 Ph: (847) 616-6900, (800) 228-1885, Fax: (847) 616-6970 www.cretors.com, postmaster@cretors.com		DESCRIPTION FLOOR SHIELD, ASSEMBLY, STANDARD	
DRAWN BY pwozny	DRAWN DATE 06/02/2020	MATERIAL REFER INDIVIDUAL SUB-PARTS	APPROX. WEIGHT 49.3 LBS
APPROVED BY ndarji	APPROVED DATE 06/02/2020	DRAWING NUMBER 22656-STD	SHEET 6 OF 6 REVISION P1