



We invented the popcorn machine
THEN JUST KEPT GOING!

176 MITTEL DRIVE, WOOD DALE, IL 60191

7700 PUMP MANUAL

**120Volt,
Single Phase, 50 Hz**

**230 Volt,
Single Phase, 50/60 Hz**

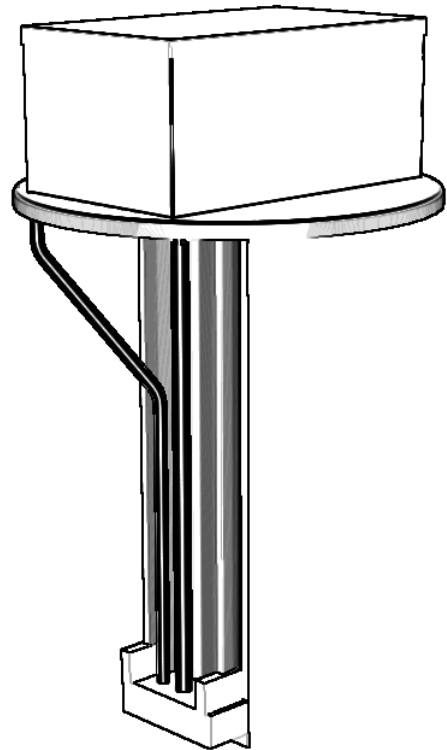

READ and UNDERSTAND these operating and safety instructions before operating this machine

SAFETY FIRST



The information in this manual is essential for the safe installation and maintenance of your Cretors oil pumps. The manual must be read and understood before installing, operating or maintaining this equipment or equivalent training must be provided.



"The employer shall instruct each employee in the recognition and avoidance of unsafe conditions and the regulations applicable to his work environment to control or eliminate any hazards or other exposure to illness or injury".
Ref.: 29 CFR 1926.20 (b)(4)(a)(2)



It is understood that safety rules within individual companies vary. If a conflict exists between the safety procedures contained in this manual and the rules of a using company, the more stringent rule should take precedence.

I INTRODUCTION

This manual contains information regarding your Cretors oil pumps. There is nothing, however, more important than the safety aids and warnings that are found throughout this document. The Safety Alert Symbol is used to identify topics of primary safety concern wherever they appear. Furthermore, a separate section has been included which deals exclusively with operation and accident prevention.

If, after reviewing this manual, anything is unclear or technical problems are encountered, contact the dealer from whom you purchased your machine for assistance; and, if there are any additional questions, feel free to contact our Customer Service Department at 800/228-1885. Always have the serial number of your machine available to assist in obtaining the correct information.

II SAFETY ALERT SYMBOL

The symbol shown below is used to call your attention to instructions concerning your personal safety and the safety of others. Watch this symbol. It points out important safety precautions. It means "ATTENTION! Become Alert! Your personal safety is involved!" Read the message that follows and be alert to the risk of personal injury or death.



III PURPOSE OF MANUAL



This instruction manual is intended to familiarize owners with the operation and safety procedures associated with your Cretors oil pumps.



This manual should be kept available to operating and maintenance personnel.



A person who has not read and understood all operating and safety instructions is not qualified to operate the machine.

IV PRODUCT IDENTIFICATION

CRETORS OIL PUMPS:

MODEL	7700 / 7700 RCA-X AUTOMATIC OIL PUMP MODEL
Capacity:	To be used on a 50 lb. Pail of oil
Electrical:	120 Volt, Single Phase, 60 Cycle, 700 Watts, 5.8 amps
Dimensions:	14-1/2" D x 14-1/2" W x 25" H (shipping)
Net Weight:	12 lbs.
Shipping Weight:	20 lbs.

MODEL	7700-SC / 7700SCA-X AUTOMATIC OIL PUMP MODEL
Capacity:	To be used on a 50 lb. Pail of oil
Electrical:	120 Volt, Single Phase, 60 Cycle, 700 Watts, 5.8 amps
Dimensions:	14-1/2" D x 14-1/2" W x 25" H (shipping)
Net Weight:	12 lbs.
Shipping Weight:	20 lbs.

MODEL	7700-E / 7700RCE-X AUTOMATIC OIL PUMP MODEL
Capacity:	To be used on a 50 lb. Pail of oil
Electrical:	230 Volts, 50/60 cycle, single phase, 700 Watts, 3.1 amps
Dimensions:	14-1/2" D x 14-1/2" W x 25" H (shipping)
Net Weight:	12 lbs.
Shipping Weight:	20 lbs.

MODEL	7700-SC-E / 7700SCE-X AUTOMATIC OIL PUMP MODEL
Capacity:	To be used on a 50 lb. Pail of oil
Electrical:	230 Volts, 50/60 cycle, single phase, 700 Watts, 3.1 amps
Dimensions:	14-1/2" D x 14-1/2" W x 25" H (shipping)
Net Weight:	12 lbs.
Shipping Weight:	20 lbs.

MODEL	7700-L / 7700SSA-X AUTOMATIC LOGIC/ SALT/SUGAR OIL PUMP MODEL
--------------	--

Capacity:	To be used on a 50 lb. Pail of oil
Electrical:	120 Volt, Single Phase, 60 Cycle, 700 Watts, 5.8 amps
Dimensions:	14-1/2"D x 14-1/2"W x 25"H (shipping)
Net Weight:	12 lbs.
Shipping Weight:	20 lbs.

MODEL	7700-E-L / 7700SSE-X AUTOMATIC LOGIC/ SALT/SUGAR OIL PUMP MODEL
--------------	--

Capacity:	To be used on a 50 lb. Pail of oil
Electrical:	230 Volts, 50/60 cycle, single phase, 700 Watts, 3.1 amps
Dimensions:	14-1/2"D x 14-1/2"W x 25"H (shipping)
Net Weight:	12 lbs.
Shipping Weight:	20 lbs.



7700 Pail Oil Pump



Part Number	Voltage	Wattage	NEMA Plug
**7700XXX-X	120v (60Hz); 230v (50Hz)	700	

Shipping Weight: 20 lbs/ Shipping Dimensions: 25in x 15in x 15in
 Metric Shipping Weight: 9 kg/ Shipping Dimensions: 64cm x 39cm x 39cm
**Actual dimensions available in technical drawing below*
***Actual part number dependant on machine features*

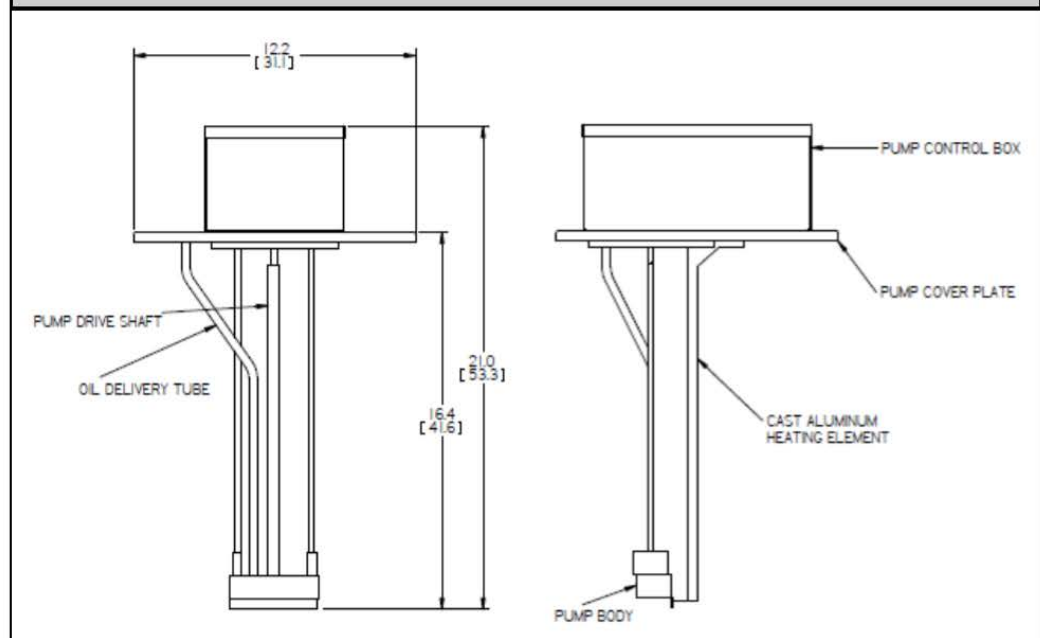

Theory and Observations of Popcorn Machine Operation

1. The efficient production of popcorn requires the presence of popcorn kernels, heat, and oil. The purpose of the oil is to distribute the heat throughout kernels evenly and quickly. If the heat is not distributed evenly and quickly, the kernels may burn instead of pop.



2. In order to pop corn in oil, the kettle, oil and parts near the heating elements are necessarily and unavoidably heated to temperatures high enough to pop popcorn. The temperature is controlled using a thermostat located inside the kettle to maintain the kettle at an operating temperature between 380-420°F.

Contact with these surfaces will burn and scald you. Do not touch the kettle, oil or parts in the direct vicinity of the heating elements.

3. The kettle is provided with an agitator to assist in the quick and even distribution of heat throughout the kernels.



4. The oil is heated to high temperatures in a kettle provided with electric heating elements to reach proper popping temperature. An operator is required in the vicinity of the kettle only when handling corn or dumping popped corn from the kettle. Neither of these operations requires direct contact with the kettle. Direct contact with the hot oil, kettle, or heating elements could result in serious burns or scalds. Keep away from the kettle whenever possible. Use the handle when dumping the kettle, and use the provided cups when necessary to measure corn, oil and salt.

5. As the popcorn pops, it will push the lid open and discharge into the cabinet. When the corn finishes popping, the corn remaining in the kettle can be removed by holding the kettle handle in your right hand and rotating down in a clockwise direction to dump the kettle.
6. Your 7700 model Cretors oil pump, which when properly adjusted, automatically delivers the proper amount of oil to the popping kettle.
7. A Cretors Hot rod is available to assist in the melting of solidified oil.

VI CONTROL SWITCH

Time Heat Switch	-turns on the heat element
Indicator light	-indicates operation of the heat element
Push button	-activates timer and motor to dispense oil
Power switch	-turns on the power to oil pump on self-contained unit

VII INSTALLATION INSTRUCTIONS

A. Location

Choose a location for your Cretors oil pump to maximize the ease of operation and maintenance procedures. Check your local building and fire codes for location restrictions.

B. Power Supply

Determine the required power supply.



Connect your dispenser only to the correct power source. Failure to do so may result in personal injury or death and may damage your machine.



C. Cretors & Co. recommends dedicated circuits for popcorn machines. The 7700-SC model pump requires a 15 amp circuit. Check your local electrical codes regarding cut-off requirements.



Make certain your popcorn machine and oil pump is properly grounded. Failure to do so may result in damage to your equipment or present a shock hazard.

C. Connecting oil pump to power source



Make certain that power supply circuit breakers are in the off position. Make certain all switches on the machine are in the off position before plugging in your 7700 model Cretors oil pumps.



Perform work only on de-energized circuits. Failure to do so may lead to electrical shock resulting in personal injury or death.

- D. Plug your machine and oil pump into the correct type of outlet, turn on the circuit breaker and then turn on the machine switches. If the motor groans, the receptacle in the 8 108 485 115 been improperly wired. Contact an Electrician.

Make certain all switches are in the off position before plugging in your Cretors popcorn machine and oil pump.

E. Pump Installation

Cretors oil pump and Hot Rod are intended for use in standard steel pails only. The following instructions assume the presence of a Deluxe or Economy base.

1. Make certain the pump switch on the control panel is in the OFF position.
2. Inserting the pump into the pail
Place the pump on top of the oil and center in the pail. If the oil is solid, the pump can be rotated clockwise/counterclockwise 90°, and the metal “blade” on the bottom of the pump will cut into the hard oil. Connect the power supply cord to the pump. The special connector will only plug in one way and it may be necessary to rotate it in order to insert it completely.

Turn on the auxiliary and pump switches and set the time heat switch to 20 or 30 minutes and allow the pump to melt itself into the oil. Proceed to step 3.



Do not overheat the oil in the pail. Once the oil is liquefied, it is not necessary to continue heating the oil. If the heat timer is continually restarted, the oil will become too hot and damage the oil tubing, becoming a source of leaks, and the hot pail a source of burns.



If any oil should spill or leak, be sure to promptly and thoroughly clean the exposed area. Failure to do so may result in a slipping hazard resulting in serious injury or death.

3. Connect the pump to the oil delivery tube by pushing the quick connect socket at the end of the delivery hose, onto the quick disconnect plug mounted on the support cover. When the plug is fully inserted, the spring will snap into place and hold the connector securely.
4. Make certain the oil delivery hose contains no low spots. Oil may solidify in such low spots and clog the hose.

F. Pump Adjustment



Make sure that the popper heat switch is off during pump adjustments. This is to avoid touching a hot kettle, which may result in serious burns.

1. To check the output adjustment, place the kettle in the dump position and hold the oil measure cup under the oil delivery tube.



Never hold the oil measure cup under the oil delivery tube if the kettle is hot. This may result in serious burns or injuries.

2. Press the delivery button and wait for the pump to cycle. Dispose of the oil, and cycle the pump again. To obtain accurate readings, let the oil drain back to the pail as it would between popping. Observe the oil in the tube to confirm that the oil has drained back to the pail.

3. After three cycles, the amount of delivered will be consistent. Check this amount with the measuring cup. Below is a good starting point to set the timer for an approximate amount of oil to be delivered. Each machine may vary.

<u>MACHINES</u>	<u>AMOUNT OF OIL</u>	<u>SET TIMER TO "X" SECONDS</u>
PT14	4.5 oz.	3 seconds
MR16	5.5 oz.	4 seconds
EG20, DI20, PR20	7.5 oz.	5 seconds
EG32, DI32, PR32, GG32	11 oz.	9 seconds
DI48		
EG48, DI48, PR48,	16 oz.	12 seconds
EG60, DI60, GG60	20 oz.	16 seconds

*Recommended pump timer settings. Machines may differ slightly.

4. If the amount of oil is not correct, it may be adjusted. To adjust the pump:
- Turn off the pump switch
 - Put the pail step in place
 - Disconnect oil hose
 - Move pail out of cabinet onto pail step. (Use a slight lifting and pulling motion)



Make sure you brace the pail step against the cabinet to avoid sliding it off the base of the cabinet when pulling the pail across it. Use proper moving techniques to avoid injury to back.

- e. To set the oil quantity delivery:
- Remove the snap out plug on top of the switch box, which is on the top of the pump, to expose the timer.
 - Check to make sure the timer has good contact by pushing down lightly on timer, making certain not to push any of the switches.
 - Switches 1 through 10 are each assigned a certain amount of seconds of delay time. Each successive switch is double the amount of delay time for the switch before it. The amounts of delay time are written at the top, along the "OPEN"/"OFF" line (i.e. 1,2,4,8, etc).
 - The switch must be in the UP position along the "OPEN"/"OFF" line for the delay time to apply. An example of this for three seconds would have the switch corresponding to the 1 on the "OPEN"/"OFF" line up along with the switch corresponding to the 2 on the "OPEN"/"OFF" line.
 - For Salt/sugar pumps, the oil time is adjusted through the timers located in the popper the same way.
 - For Logic pumps, the oil time is adjusted through the Logic board. Please refer to your machine manual.

To turn the dip switches ON the dip switch needs to be pressed down to the number side opposite of the open side.

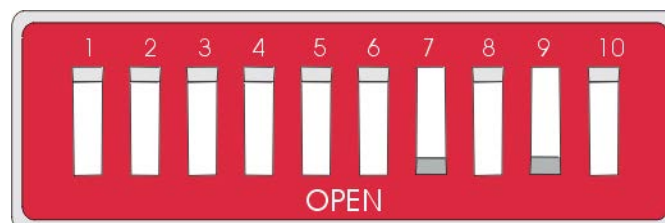

Switch #1	= 1 seconds
#2	= 2 seconds
#3	= 4 seconds
#4	= 8 seconds
#5	= 16 seconds

Example: If you turn #3 and #4 on, the time delay will be 12 seconds.

- f. Install snap out plug (which was removed in first step in section e).



Move pail back into cabinet. Use proper moving techniques to avoid injury to back.

- g. Connect oil hose by snapping in place.
- h. Remove pail step and place in bottom of cabinet for easy access in future.
- i. Turn on the pump switch and re-check the oil output using steps 1 thru 4 in the Pump Adjustment section.

VIII OPERATING INSTRUCTIONS



Do not attempt to operate your Cretors popcorn machine or oil pumps until you have read and understood this manual. Failure to do so may result in serious injury or death.



Do not attempt to operate your Cretors popcorn machine or oil pumps unless the installation instructions have been strictly adhered to. Failure to do so may result in serious injury or death.



Operate your popcorn machine and oil pump only if it is in sanitary condition. Failure to do so may result in illness to your customers.



Always turn off the kettle heat switch when no popping corn. Failure to do so will cause oil to stain the kettle, possibly resulting in an unsanitary condition. It may also cause a “flash” fire if oil is added to a kettle left unattended with the heat on, resulting in serious burns or death.

To operate your Cretors 7700 oil pump:

1. Turn on pump switch



NOTE: Avoid contact with the kettle when adding corn or salt. ALWAYS ADD CORN TO THE KETTLE BEFORE ADDING OIL. FAILURE TO DO SO MAY RESULT IN THE OIL BEING HEATED TOO RAPIDLY RESULTING IN A FIRE.

2. Push the oil pump button which will provide the correct amount of oil based on previously setting and testing the timer.
3. When the oil bucket is empty, insert the oil pump into a new bucket as described in the Installation Section.



Follow the recommended sanitation procedures.

IX TROUBLE SHOOTING AND SERVICE INSTRUCTIONS



In the case of improper operation, qualified personnel only should perform the following diagnostic checks, and, if necessary, corresponding adjustments and repairs. All of the following procedures present an electrical shock hazard and can cause serious injury or death

1. Nothing works:
QUESTION: Is the pump plugged in?
QUESTION: Is the machine plugged in?
2. Pump not heating:
 - a. No indicator light or heat - check heat timer
 - b. Indicator light, but no heat - check element
3. Heat will not go off:
Bad heat timer - replace.
4. Motor hums, but will not turn:
 - a. Hard oil - melt oil
 - b. Drive shaft does not turn freely - may have been dropped on element causing discharge tube to jam into pump gears - clear jam
 - c. Motor bad - replace
5. Pump runs all the time:
 - a. Timer set incorrectly - rest (See Pump Adjustment)

- b. Bad timer - replace
6. Solid oil in pail:
Melt the oil in the pail by turning the time heat switch (2012) on the pump. For Logic, press "Oil Heat" button on Logic board. Make sure Logic is set for 7700 Pump.
 7. Motor runs, but does not dispense oil:
 - a. Check for oil in the pail - refill
 - b. Discharge tube (2566) pulled out of pump body
 - c. Solid oil in line - the oil in the tube may be melted with a rag soaked in hot water and wrapped around tube. A hair dryer may also be used to heat the tube

X SANITATION INSTRUCTIONS



Be certain the machine is turned 'OFF' and power is unplugged before sanitizing this machine unless a specific cleaning procedure requires power to the machine. Failure to do so could result in injury or death.



Do not clean heated surfaces until they have been given sufficient time to cool. Failure to do so may result in serious burns or scalds.

The pump is most easily cleaned by using two empty popping oil pails or buckets that have been thoroughly cleaned of oil. The cleaning procedure is:

1. Fill one pail ½ full of hot water and mix in ½ package of CKC (Cretors Kettle Cleaner).
2. Put the pump on the pail and turn on the heat timer to 20 minutes and leave until the water is hot.
3. Unplug the pump and hold the pump over the pail. Clean the outside of the pump and heating element. Do not immerse the pump motor or get the top plate and motor wet. Put the pump on the pail again, and reconnect the electrical power supply and oil line.
4. Put the kettle in the dump position, and place a container under the oil discharge tube to catch the cleaning water.
5. Cycle the pump several times catching the cleaning water in the empty container.
6. Disconnect the pump. Take the pump to a sink and thoroughly rinse the pump and heat element.



Do not get the top of the pump wet. Electrical shorts and a shock hazard, which can cause injury, from the result of the wires inside the top of the pump getting wet.

7. Take a second pail and fill it with clean water. If only one pail is available, empty the soapy water from the pail, rinse it completely and fill it with clean water.

8. Reconnect the pump, and cycle it several times to thoroughly rinse the inside of the pump and oil lines.
9. Allow the pump and oil lines to drain.
10. After draining pump and oil lines, reconnect the pump and cycle oil once to prevent rust in the pump.

This manual is filled with timesaving and money-saving information regarding your Cretors popcorn machine. There is nothing, however, more important than the safety aids and warnings found throughout this document.

If you have any questions, feel free to contact our Customer Service at 800/228-1885.

Additional copies of this manual can be obtained from Customer Service.

Cretors warrants this machine to be free of defects in parts, materials and workmanship for two years. Please fill out and return the registration card to activate your warranty. If you have questions concerning the warranty, please contact Customer Service at 800/228-1885.

7700 REMOTE PUMP -120V
 BEGINNING SERIAL # 99021307

DOC: 77300001

7700-A-1.0-A
 08/01

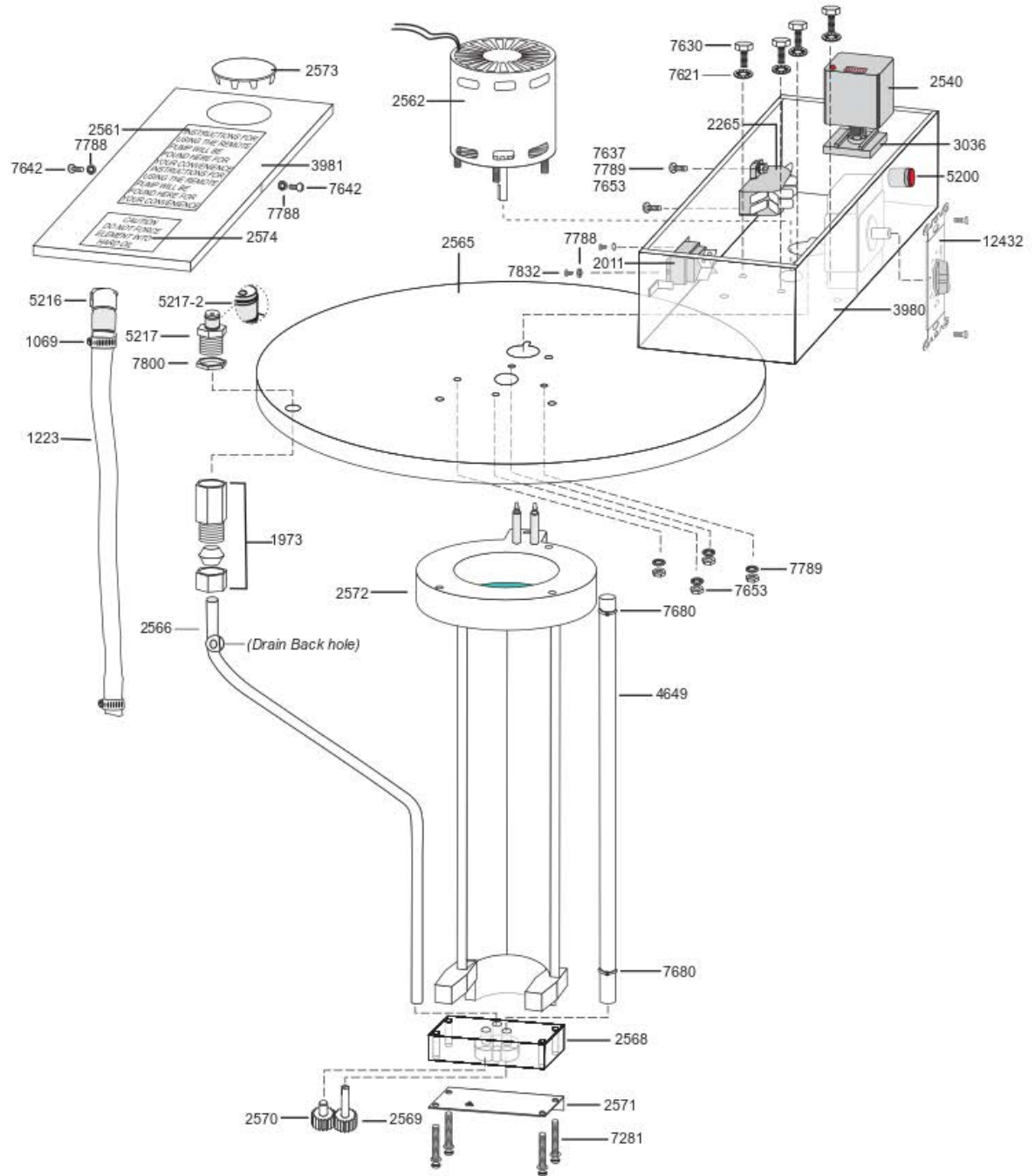

C. CRETORS AND COMPANY

7700 REMOTE PUMP -120V
 BEGINNING SERIAL # 99021307

DOC: 77300001

7700-A-1.0-A
08/01

1069	CLAMP - HOSE	7800	1/4" NPT HEX THIN NUT
1223	TUBING - NALGENE SOLD PER FOOT	7832	8-32 x 1/4 BINDING HEAD
1973	1/4" NPT TO 3/8" TUBE SS	12432	SWITCH - TIME HEAT
2011	PUMP RECEPTACLE		
2540	TIMER PLUG IN - 120V		
2265	TERMINAL BLOCK-2 PIN		
2561	DECAL -PUMP INSTRUCTIONS		
2562	PUMP MOTOR - 120V		
2562-C	PUMP MOTOR - 230V		
2565	PUMP SUPPORT COVER		
2566	OIL INLET TUBE		
2568	PUMP BODY		
2569	PUMP DRIVE GEAR (LONG)		
2570	PUMP IDLER GEAR (SHORT)		
2571	PUMP BODY COVER		
2572	PUMP HEAT ELEMENT - 120V		
2573	HOLE COVER W/ "O" RING		
2574	CAUTION-DECAL		
3036	RELAY BASE - 8PIN		
3980	PUMP BOX - 120V		
3981	PUMP BOX COVER 120V		
4649	PUMP SHAFT		
5200	INDICATOR LIGHT		
5216	QUICK CONNECT SOCKET		
5217	QUICK DISCONNECT PLUG		
5217-2	"O" RING ONLY		
7281	8-32 x 1-1/2 THUMB SCREW		
7621	1/4 INTERNAL TOOTH LOCKWASHER		
7630	1/4 x 20 x 1/2 HEX BOLT		
7637	8-32 x 1/2 SS TRUSS HEAD		
7642	8-32 x 3/8 SS TRUSS HEAD		
7653	8-32 HEX NUT		
7680	1/8 x 3/4 'T' COTTER PIN		
7788	#6 LOCKWASHER		
7789	#8 STARLOCKWASHER		

 C. CRETORS AND COMPANY

7700 REMOTE PUMP SELF CONTAINED - 230V
 BEGINNING SERIAL No. 99043442

DOC: 77300003

7700-SC-E-1.0-A
 03/2000

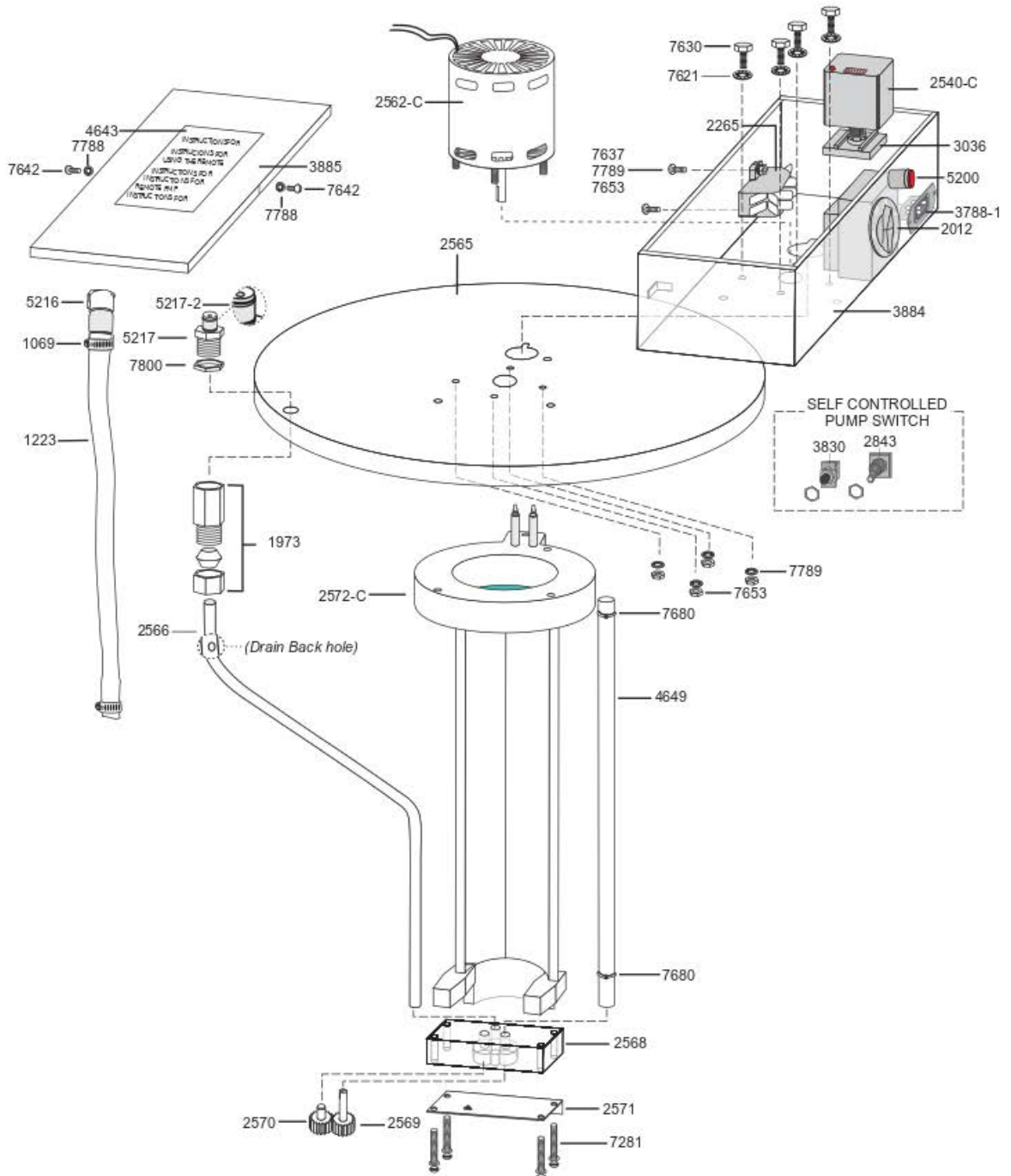

C. CRETORS AND COMPANY

7700 REMOTE PUMP SELF CONTAINED - 230V
 BEGINNING SERIAL No. 99043442

DOC: 77300003

7700-SC-E-1.0-A
03/2000

1069	CLAMP - HOSE	7788	#6 LOCKWASHER
1223	TUBING - NALGENE SOLD PER FOOT	7800	1/4" NPT HEX THIN NUT
1973	1/4" NPT TO 3/8" TUBE SS		
2012	SWITCH - TIME HEAT		
2265	TERMINAL BLOCK-2 PIN		
2540-C	TIMER PLUG IN - 230V		
2562-C	PUMP MOTOR - 230V		
2565	PUMP SUPPORT COVER		
2566	OIL INLET TUBE		
2568	PUMP BODY		
2569	PUMP DRIVE GEAR (LONG)		
2570	PUMP IDLER GEAR (SHORT)		
2571	PUMP BODY COVER		
2572-C	PUMP HEAT ELEMENT - 240V		
2573	HOLE COVER W/ "O" RING		
2843	SWITCH-DOUBLE POLE		
3036	RELAY BASE - 8PIN		
3788-1	IEC 320 POER INLET - SCREW MOUNT		
3827	RECEPTACLE ASSY - 230V PUMP		
3830	SWITCH-PUSH BUTTON		
3885	PUMP BOX COVER 230V		
3884	PUMP BOX - 230V SC		
4643	DECAL - PUMP INSTRUCTIONS-INTL		
4649	PUMP SHAFT		
5200	INDICATOR LIGHT		
5216	QUICK CONNECT SOCKET		
5217	QUICK DISCONNECT PLUG		
5217-2	"O" RING ONLY		
7281	8-32 x 1-1/2 THUMB SCREW		
7621	1/4 INTERNAL TOOTH LOCKWASHER		
7630	1/4 x 20 x 1/2 HEX BOLT		
7637	8-32 x 1/2 SS TRUSS HEAD		
7642	8-32 x 3/8 SS TRUSS HEAD		
7653	8-32 HEX NUT		
7680	1/8 x 3/4 "T" COTTER PIN		

 C. CRETORS AND COMPANY

7700 REMOTE PUMP SELF CONTAINED - 230V - SHORT
 BEGINNING SERIAL No. 0305

DOC: 77300004

7700S-SC-E-1.0-A
 05/2003

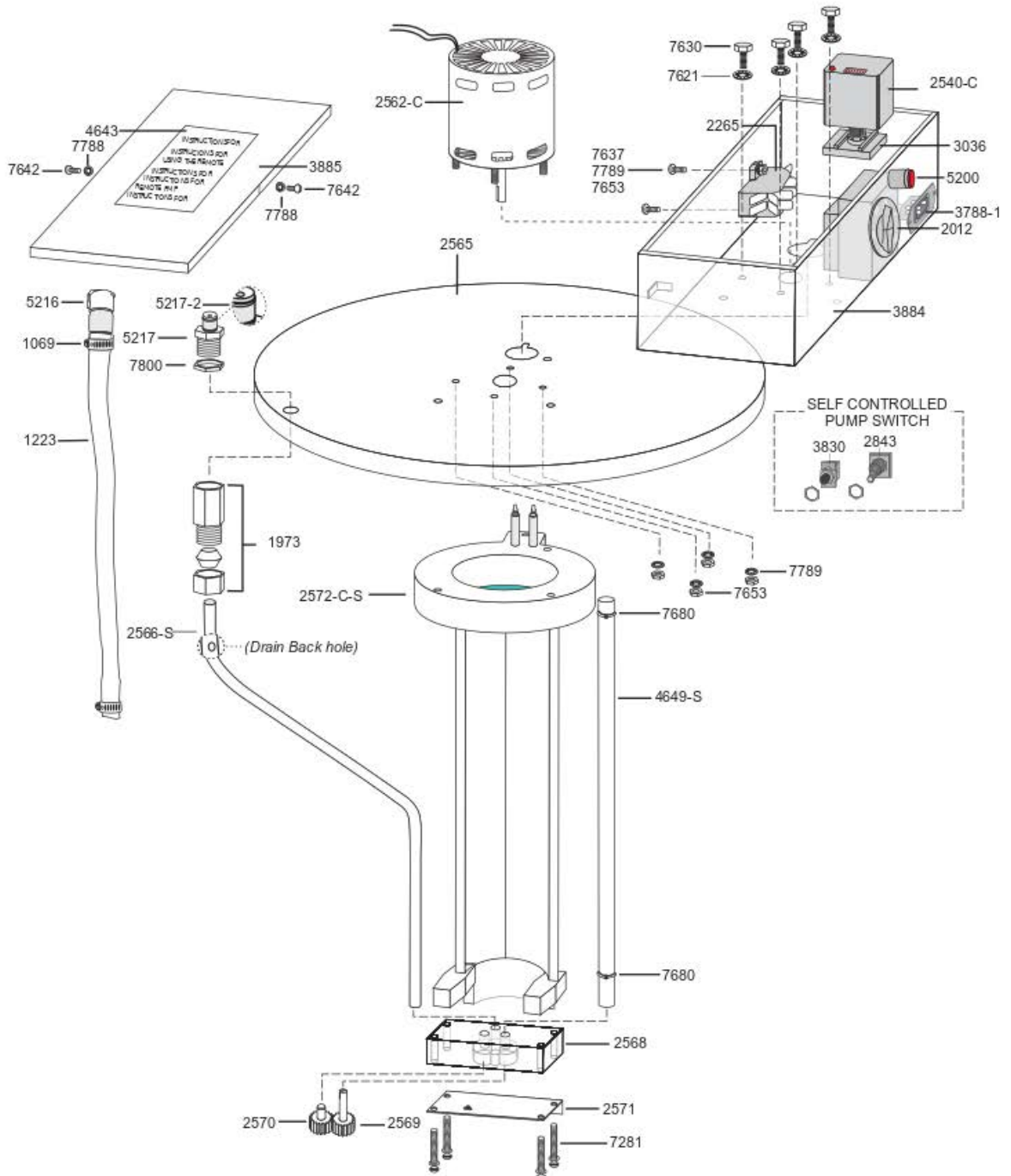

C. CRETORS AND COMPANY

7700 REMOTE PUMP SELF CONTAINED - 230V - SHORT
 BEGINNING SERIAL No. 0305

DOC: 77300004

7700S-SC-E-1.0-A
05/2003

1069	CLAMP - HOSE	7788	#6 LOCKWASHER
1223	TUBING - NALGENE SOLD PER FOOT	7800	1/4" NPT HEX THIN NUT
1973	1/4" NPT TO 3/8" TUBE SS		
2012	SWITCH - TIME HEAT		
2265	TERMINAL BLOCK-2 PIN		
2540-C	TIMER PLUG IN - 230V		
2562-C	PUMP MOTOR - 230V		
2565	PUMP SUPPORT COVER		
2566-S	OIL INLET TUBE		
2568	PUMP BODY		
2569	PUMP DRIVE GEAR (LONG)		
2570	PUMP IDLER GEAR (SHORT)		
2571	PUMP BODY COVER		
2572-C-S	PUMP HEAT ELEMENT - 240V		
2573	HOLE COVER W/ "O" RING		
2843	SWITCH-DOUBLE POLE		
3036	RELAY BASE - 8PIN		
3788-1	IEC 320 POER INLET - SCREW MOUNT		
3827	RECEPTACLE ASSY - 230V PUMP		
3830	SWITCH-PUSH BUTTON		
3885	PUMP BOX COVER 230V		
3884	PUMP BOX - 230V SC		
4643	DECAL - PUMP INSTRUCTIONS-INTL		
4649-S	PUMP SHAFT		
5200	INDICATOR LIGHT		
5216	QUICK CONNECT SOCKET		
5217	QUICK DISCONNECT PLUG		
5217-2	"O" RING ONLY		
7281	8-32 x 1-1/2 THUMB SCREW		
7621	1/4 INTERNAL TOOTH LOCKWASHER		
7630	1/4 x 20 x 1/2 HEX BOLT		
7637	8-32 x 1/2 SS TRUSS HEAD		
7642	8-32 x 3/8 SS TRUSS HEAD		
7653	8-32 HEX NUT		
7680	1/8 x 3/4 T' COTTER PIN		

 C. CRETORS AND COMPANY

7700 REMOTE PUMP SELF CONTAINED - 120V - SHORT
 BEGINNING SERIAL No. 0305

DOC: 77300005

7700S-SC-A-1.0-A
 05/2003

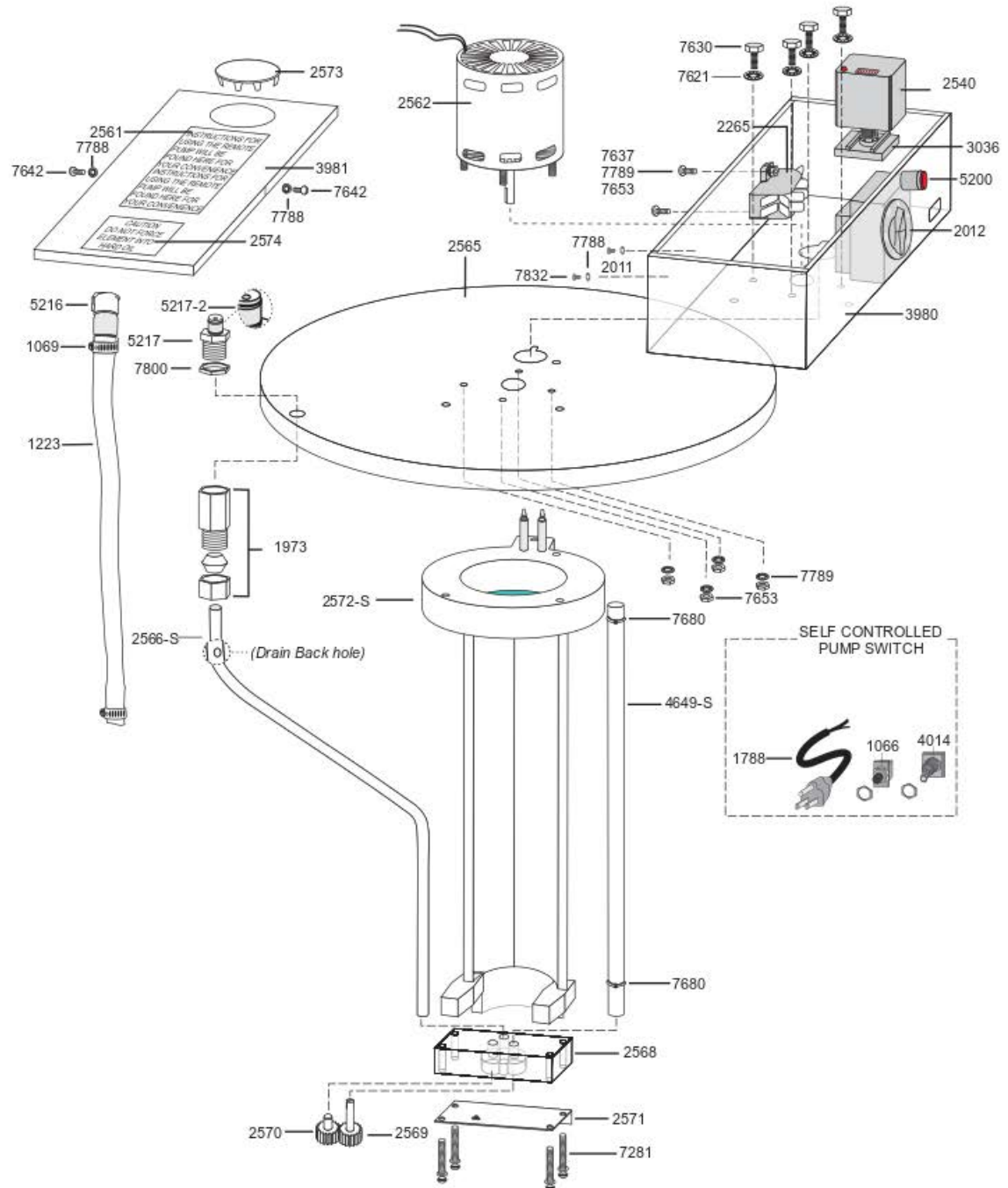

C. CRETORS AND COMPANY

7700 REMOTE PUMP SELF CONTAINED - 120V - SHORT
 BEGINNING SERIAL No. 0305

DOC: 77300005

7700S-SC-A-1.0-A
05/2003

1069	CLAMP - HOSE	1255	CONNECTOR 3/8"
1223	TUBING - NALGENE SOLD PER FOOT	1788	CORD 10 AMP, 16-3,NEMA 5-15P
1973	1/4" NPT TO 3/8" TUBE SS	1881	DECAL - PUMP DELIVER ON-OFF
2011	PUMP RECEPTACLE	2105	SWITCH PLATE - SC PUMP 120V
2012	SWITCH - TIME HEAT	4014	SWITCH (SPST, 20A, 120V)
2265	TERMINAL BLOCK-2 PIN		
2540	TIMER PLUG IN - 230V		
2562	PUMP MOTOR - 120V		
2565	PUMP SUPPORT COVER		
2566-S	OIL INLET TUBE		
2568	PUMP BODY		
2569	PUMP DRIVE GEAR (LONG)		
2570	PUMP IDLER GEAR (SHORT)		
2571	PUMP BODY COVER		
2572-S	PUMP HEAT ELEMENT - 120V		
2573	HOLE COVER W/ "O" RING		
3036	RELAY BASE - 8PIN		
3981	PUMP BOX COVER 120V		
3980	PUMP BOX - 120V SC		
4649-S	PUMP SHAFT		
5200	INDICATOR LIGHT		
5216	QUICK CONNECT SOCKET		
5217	QUICK DISCONNECT PLUG		
5217-2	"O" RING ONLY		
7281	8-32 x 1-1/2 THUMB SCREW		
7621	1/4 INTERNAL TOOTH LOCKWASHER		
7630	1/4 x 20 x 1/2 HEX BOLT		
7637	8-32 x 1/2 SS TRUSS HEAD		
7642	8-32 x 3/8 SS TRUSS HEAD		
7653	8-32 HEX NUT		
7680	1/8 x 3/4 T' COTTER PIN		
7788	#6 LOCKWASHER		
7800	1/4" NPT HEX THIN NUT		
7572-A	SELF CONTAINED PUMP PARTS - 120V		
1066	SWITCH - PUSH BUTTON		

 C. CRETORS AND COMPANY

7700 REMOTE PUMP - 230V
 BEGINNING SERIAL # 01037830

DOC: 77300005

7700-A-1.0-A
 08/01

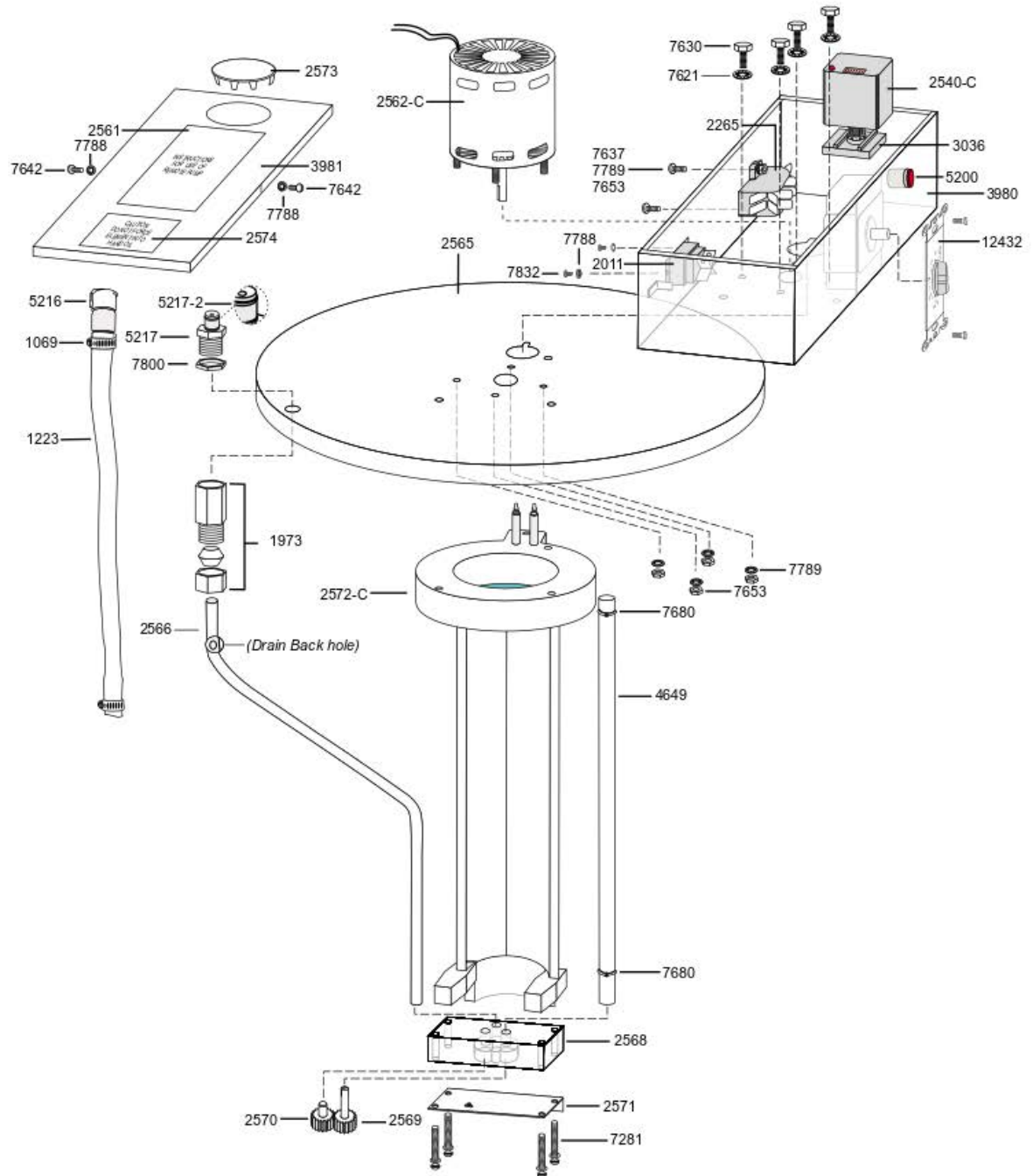

C. CRETORS AND COMPANY

7700 REMOTE PUMP - 230V

BEGINNING SERIAL # 01037830

DOC: 77300005

7700-A-1.0-A
08/01

1069	CLAMP - HOSE	7800	1/4" NPT HEX THIN NUT
1223	TUBING - NALGENE SOLD PER FOOT	7832	8-32 x 1/4 BINDING HEAD
1973	1/4" NPT TO 3/8" TUBE SS	12432	TIMER - SPRING WOUND
2011	PUMP RECEPTACLE		
2540	TIMER-PLUG IN - 230V		
2265	TERMINAL BLOCK-2 PIN		
2561	DECAL -PUMP INSTRUCTIONS		
2562	PUMP MOTOR - 230V		
2562-C	PUMP MOTOR - 230V		
2565	PUMP SUPPORT COVER		
2566	OIL INLET TUBE		
2568	PUMP BODY		
2569	PUMP DRIVE GEAR (LONG)		
2570	PUMP IDLER GEAR (SHORT)		
2571	PUMP BODY COVER		
2572	PUMP HEAT ELEMENT - 240V		
2573	HOLE COVER W/ "O" RING		
2574	CAUTION-DECAL		
3036	RELAY BASE - 8PIN		
3980	PUMP BOX - 120V		
3981	PUMP BOX COVER 120V		
4649	PUMP SHAFT		
5200	INDICATOR LIGHT		
5216	QUICK CONNECT SOCKET		
5217	QUICK DISCONNECT PLUG		
5217-2	"O" RING ONLY		
7281	8-32 x 1-1/2 THUMB SCREW		
7621	1/4 INTERNAL TOOTH LOCKWASHER		
7630	1/4 x 20 x 1/2 HEX BOLT		
7637	8-32 x 1/2 SS TRUSS HEAD		
7642	8-32 x 3/8 SS TRUSS HEAD		
7653	8-32 HEX NUT		
7680	1/8 x 3/4 'T' COTTER PIN		
7788	#6 LOCKWASHER		
7789	#8 STARLOCKWASHER		

7700 REMOTE PUMP-LOGIC
 BEGINNING SERIAL 98042270-120V, 230V

DOC: 77L30001

7700L-A/E-1.0-A
 3/99

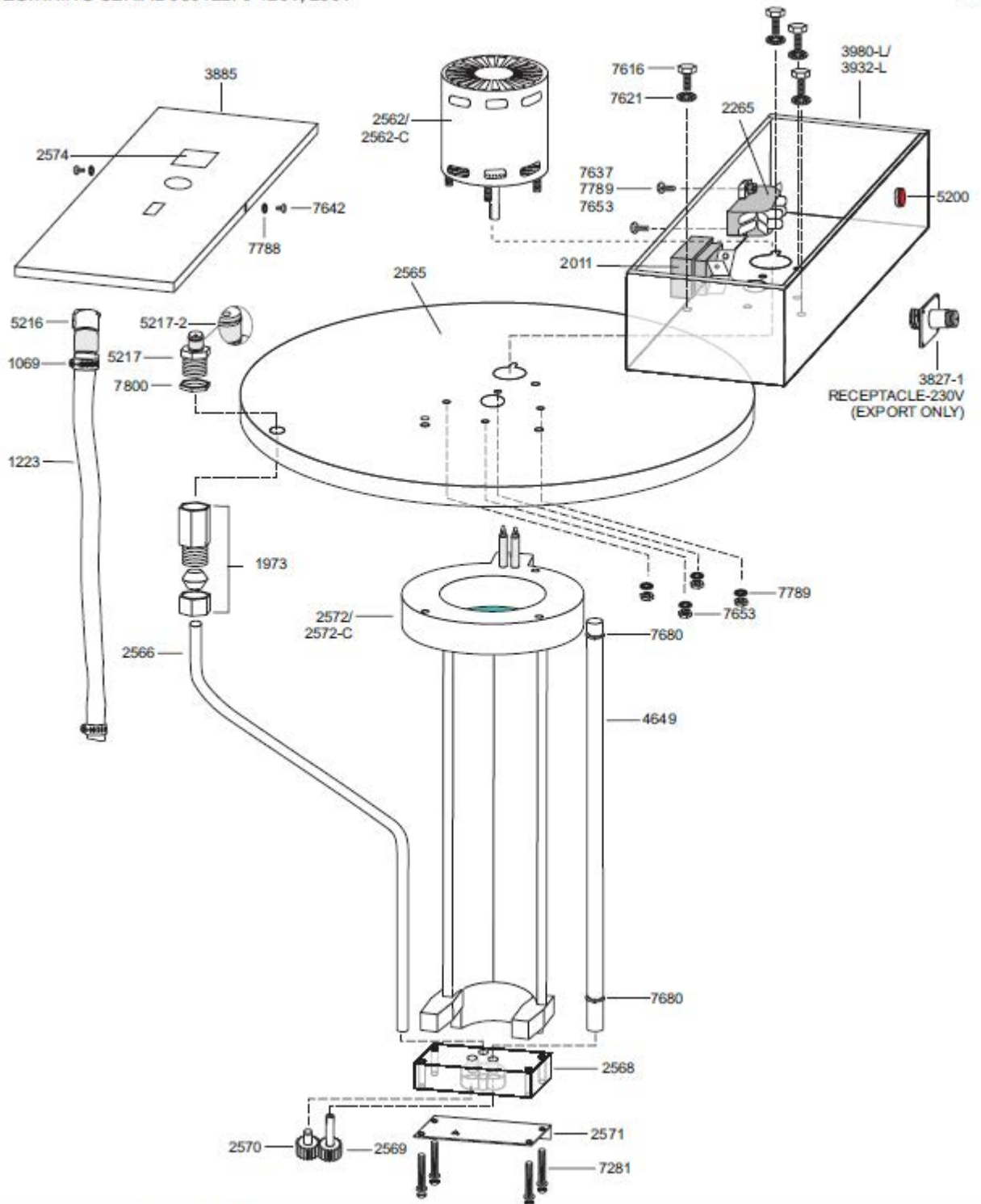

C. CRETORS AND COMPANY

7700 REMOTE PUMP-LOGIC

BEGINNING SERIAL 98042270-120V, 230V

DOC: 77L30001

7700L-A/E-1.0-A
3/99

1069	CLAMP - HOSE
1223	TUBING - NALGENE SOLD PER FOOT
1973	1/4" NPT TO 3/8" TUBE SS
2011	PUMP RECEPTACLE
2265	TERMINAL BLOCK-2 PIN
2562	PUMP MOTOR - 120V
2562-C	PUMP MOTOR - 230V
2565	PUMP SUPPORT COVER
2566	OIL INLET TUBE
2568	PUMP BODY
2569	PUMP DRIVE GEAR (LONG)
2570	PUMP IDLER GEAR (SHORT)
2571	PUMP BODY COVER
2572	PUMP HEAT ELEMENT - 120V
2572-C	PUMP HEAT ELEMENT - 230V
2574	CAUTION-DECAL
3827-1	RECEPTACLE ONLY-230V
3885	PUMP BOX COVER - 230V OR LOGIC
3932-L	PUMP BOX - 230V LOGIC
3980-L	PUMP BOX - 120V - LOGIC
4649	PUMP SHAFT
5200	INDICATOR LIGHT
5216	QUICK CONNECT SOCKET
5217	QUICK DISCONNECT PLUG
5217-2	"O" RING
7281	8-32 x 1-1/2 THUMB SCREW
7617	1/4-20 x 3/4 HEX HEAD
7637	8-32 x 1/2 SS TRUSS HEAD
7642	8-32 x 3/8 SS TRUSS HEAD
7653	8-32 HEX NUT
7680	1/8 x 3/4 "T" COTTER PIN
7788	#6 LOCKWASHER
7789	#8 STARLOCKWASHER
7800	1/4" NPT HEX THIN NUT

7700 REMOTE CONTROL PUMP
 WIRING DIAGRAM - 100/120V - 50/60 Hz
 BEGINING SERIAL NO. 1903

DOC: 7700Ar1

03/2019

MACHINE CIRCUIT

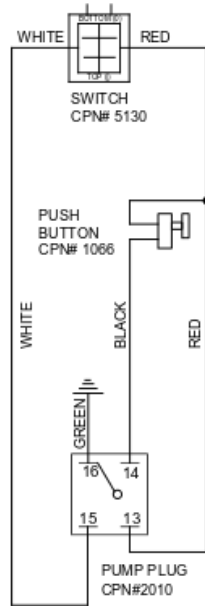

PUMP CIRCUIT

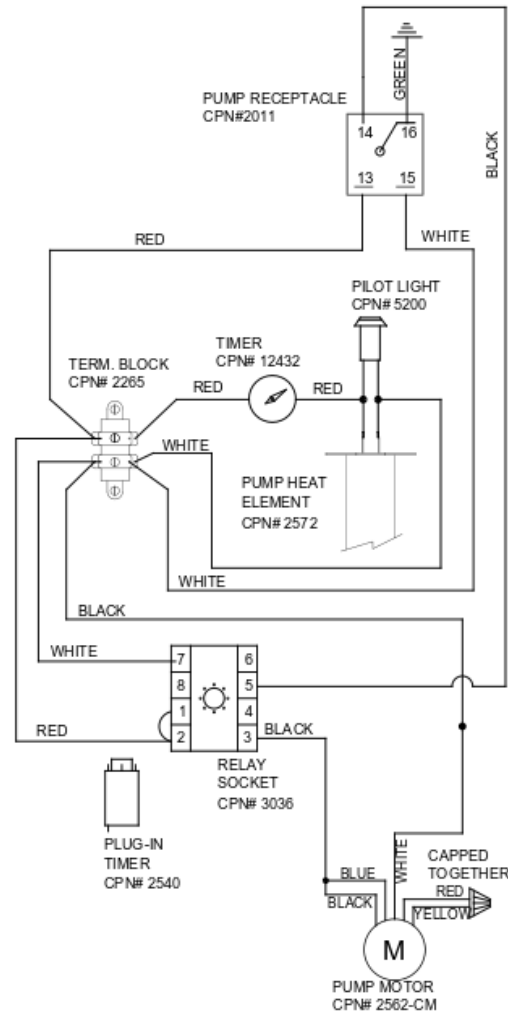

C.CRETORS AND COMPANY
 170 MITTLE DRIVE
 WOOD DALE, ILLINOIS 60191
 PHONE(847)616-6900, (800)228-1885, FAX (847)616-6970
 WEB SITE: <http://www.cretors.com> Email: postmaster@cretors.com

DOC: 7700Ar1

7700 SELF CONTAINED PUMP
 WIRING DIAGRAM - 120V/60Hz.
 BEGINING SERIAL NO. 1705

DOC: 7700ASCr2

05/2017

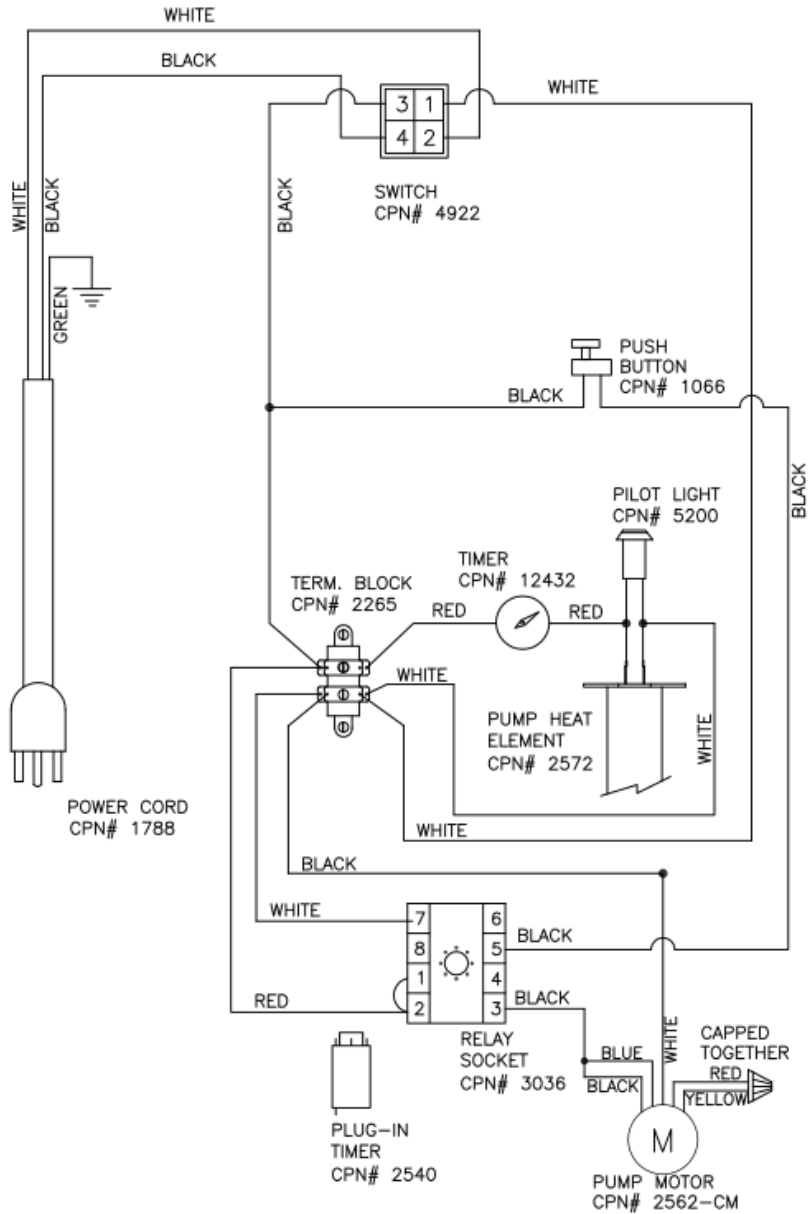

C.CRETORS AND COMPANY
 170 MITTEL DRIVE
 WOOD DALE, ILLINOIS 60191
 PHONE(847)616-6900, (800)228-1885, FAX (847)616-6970
 WEB SITE: <http://www.cretors.com> Email: postmaster@cretors.com

7700 REMOTE CONTROL PUMP - SALT/SUGAR
 WIRING DIAGRAM - 100V-120V 60Hz.
 BEGINING SERIAL NO. 1705

DOC: 7700ASSRCr2

05/2017

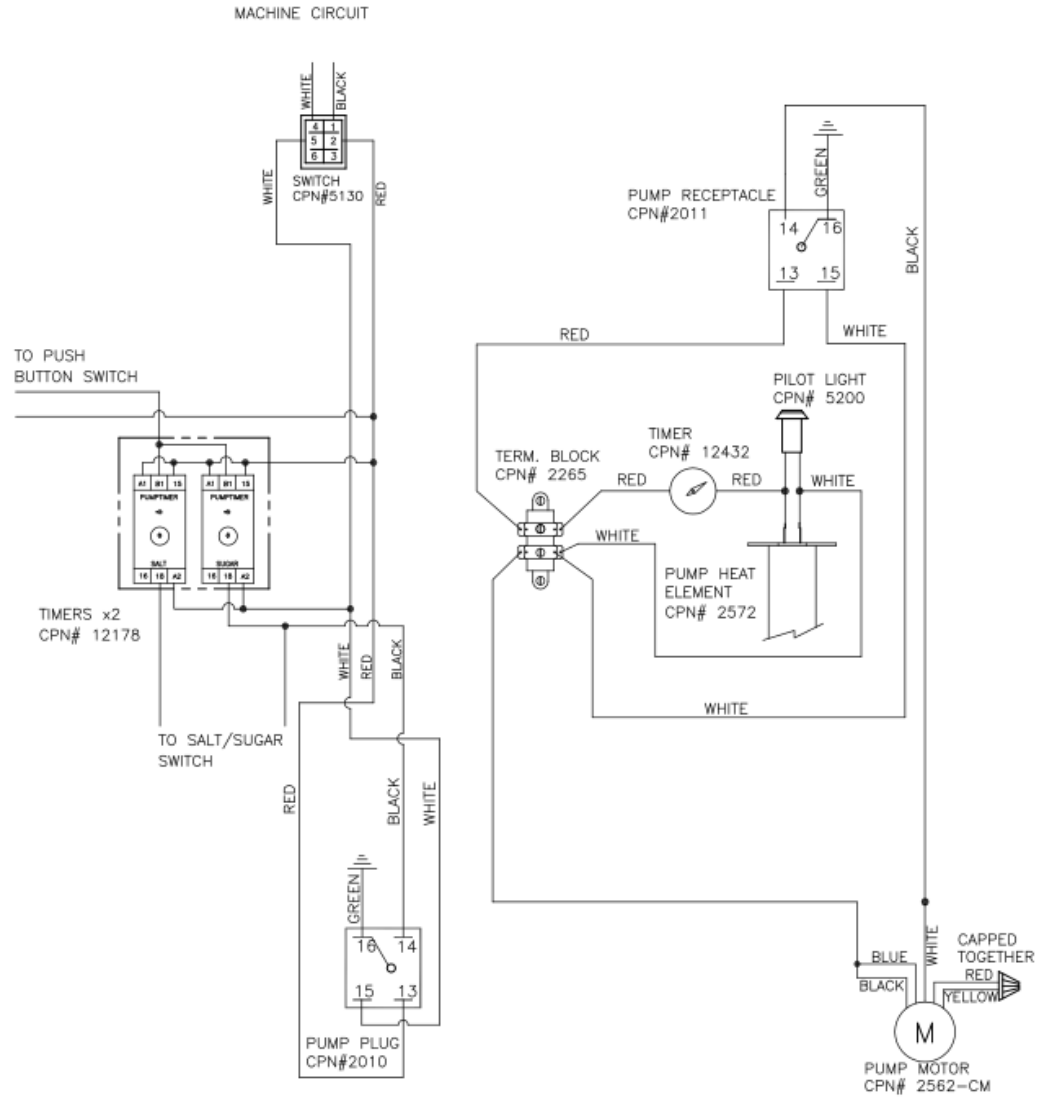

C.CRETORS AND COMPANY
 170 MITTEL DRIVE
 WOOD DALE, ILLINOIS 60191
 PHONE(847)616-6900, (800)228-1885, FAX (847)616-6970
 WEB SITE: <http://www.cretors.com> Email: postmaster@cretors.com

7700 REMOTE CONTROL PUMP
 WIRING DIAGRAM - 230V 50Hz
 BEGINING SERIAL NO. 1903

DOC: 7700Er1

03/2019

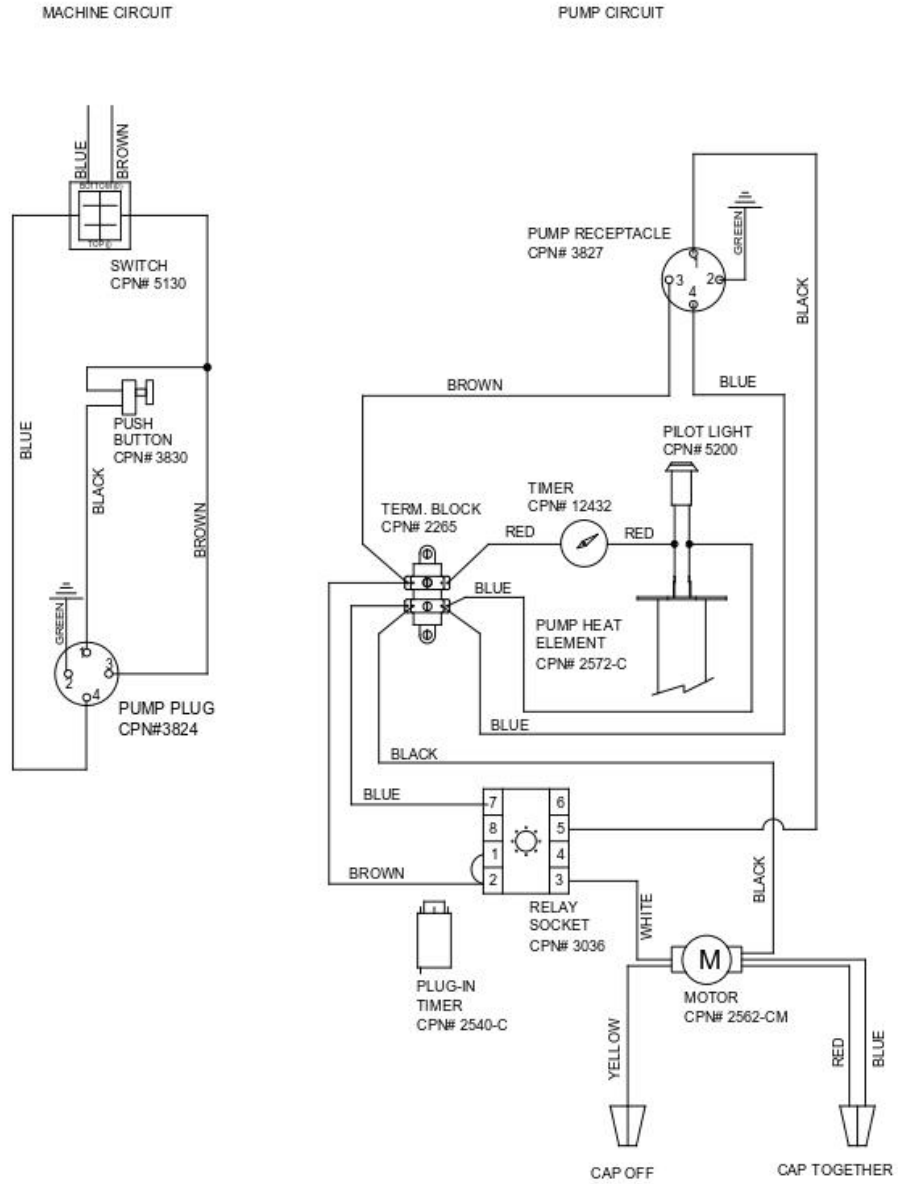

C.CRETORS AND COMPANY
 170 MITTLE DRIVE
 WOOD DALE, ILLINOIS 60191
 PHONE(847)616-6900, (800)228-1885, FAX (847)616-6970
 WEB SITE: <http://www.cretors.com> Email: postmaster@cretors.com

DOC: 7700Er1

7700 SELF CONTAINED PUMP
 WIRING DIAGRAM - 220V 50Hz.
 BEGINING SERIAL NO. 1705

DOC: 7700ESCr3

05/2017

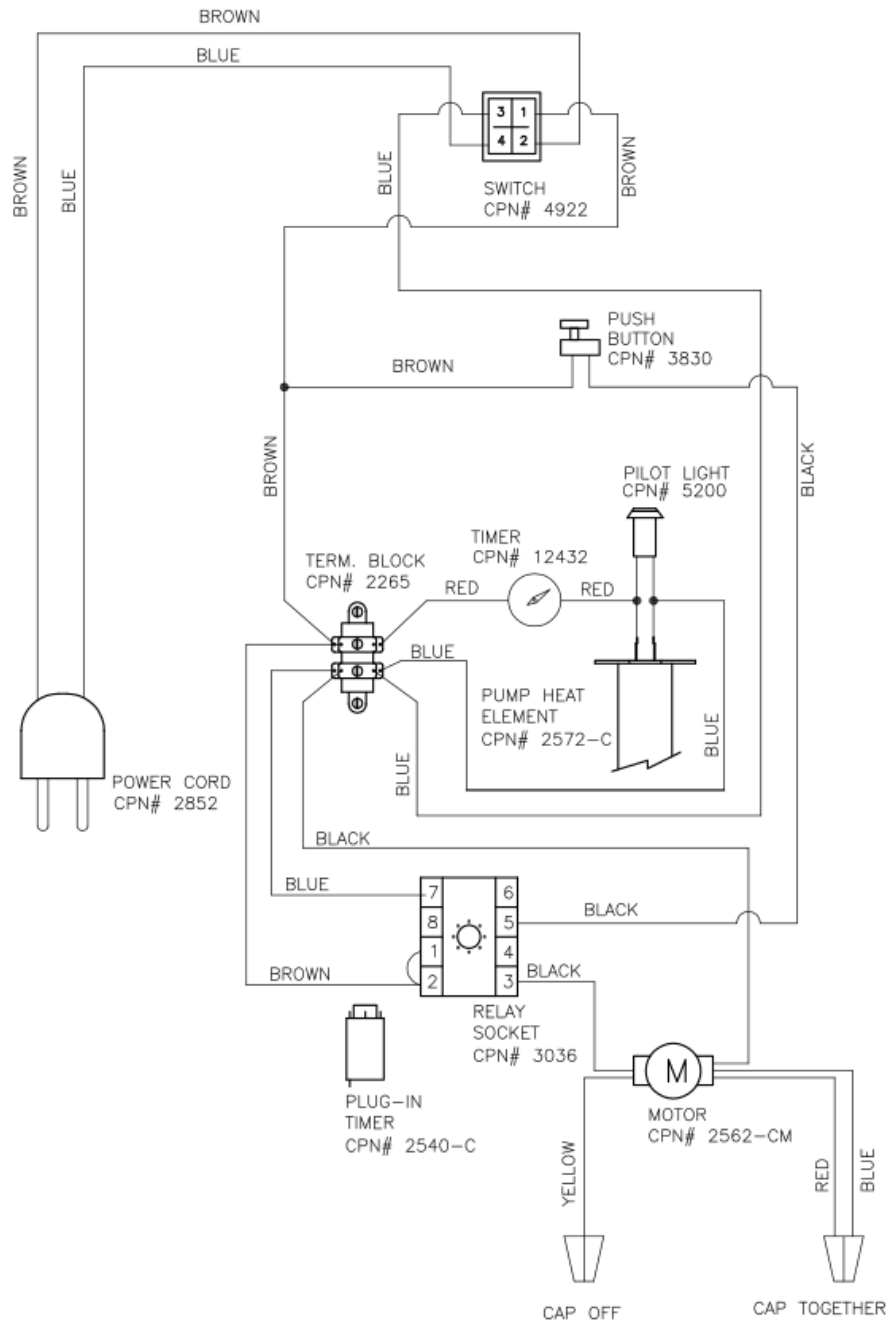

C.CRETORS AND COMPANY
 170 MITTEL DRIVE
 WOOD DALE, ILLINOIS 60191
 PHONE(847)616-6900, (800)228-1885, FAX (847)616-6970
 WEB SITE: <http://www.cretors.com> Email: postmaster@cretors.com

7700 REMOTE CONTROL PUMP SALT/SUGAR
 WIRING DIAGRAM - 230V 50Hz
 BEGINING SERIAL NO. 1507

DOC: 7700ESSr2

07/2015

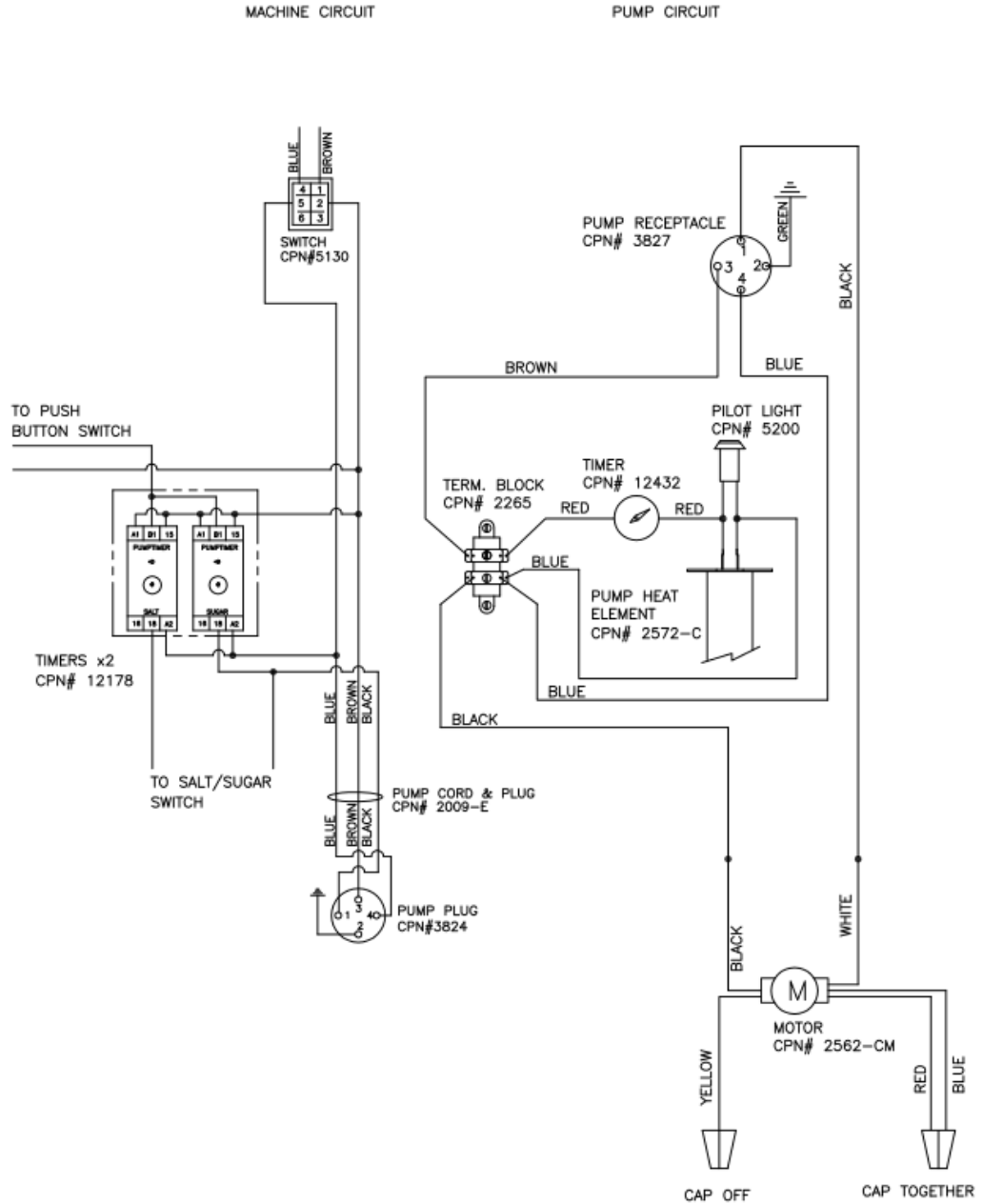

C.CRETORS AND COMPANY
 170 MITTEL DRIVE
 WOOD DALE, ILLINOIS, 60191
 PHONE(847)616-6900, (800)228-1885, FAX (847)616-6970
 WEB SITE: <http://www.cretors.com> Email: postmaster@cretors.com

THIS PAGE IS INTENTIONALLY BLANK



**We invented the popcorn machine
THEN JUST KEPT GOING!**

OIL PUMP MANUAL OPERATION & SERVICE FOR MODELS 7700 & 7900

C. CRETORS AND COMPANY



READ and UNDERSTAND these operating and safety instructions before operating this machine

**176 MITTEL DRIVE
WOOD DALE, IL 60191
PHONE: (847)616-6900, (800)228-1885, FAX(847) 616-6970**

TABLE OF CONTENTS

<i>PAGE #</i>	<i>CONTENTS</i>
3	7700 PUMP MANUAL
16	7700 PARTS DIAGRAMS AND BOM
27	7700 ELECTRICAL DIAGRAMS
33	7900 BAG-N-BOX MANUAL
47	7900 PARTS DIAGRAMS AND BOM
57	7900 ELECTRIC DIAGRAMS
61	WARRANTY REGISTRATION



We invented the popcorn machine
THEN JUST KEPT GOING!

176 MITTEL DRIVE, WOOD DALE, IL 60191

7700 PUMP MANUAL

120Volt,
Single Phase, 50 Hz

230 Volt,
Single Phase, 50/60 Hz

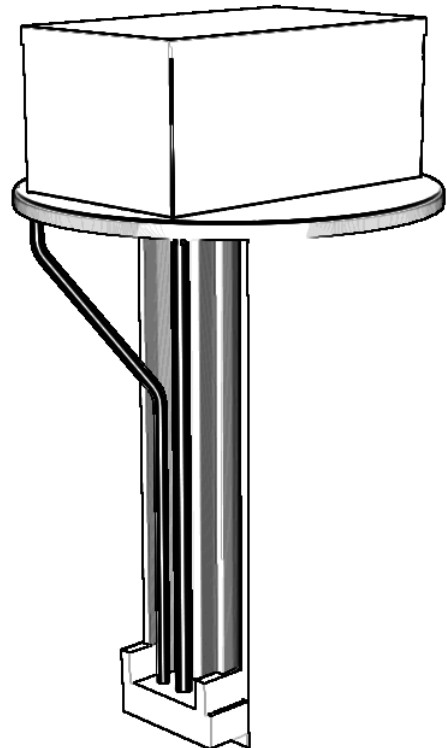

READ and UNDERSTAND these operating and safety instructions before operating this machine

SAFETY FIRST



The information in this manual is essential for the safe installation and maintenance of your Cretors oil pumps. The manual must be read and understood before installing, operating or maintaining this equipment or equivalent training must be provided.



"The employer shall instruct each employee in the recognition and avoidance of unsafe conditions and the regulations applicable to his work environment to control or eliminate any hazards or other exposure to illness or injury".
Ref.: 29 CFR 1926.20 (b)(4)(a)(2)



It is understood that safety rules within individual companies vary. If a conflict exists between the safety procedures contained in this manual and the rules of a using company, the more stringent rule should take precedence.

I INTRODUCTION

This manual contains information regarding your Cretors oil pumps. There is nothing, however, more important than the safety aids and warnings that are found throughout this document. The Safety Alert Symbol is used to identify topics of primary safety concern wherever they appear. Furthermore, a separate section has been included which deals exclusively with operation and accident prevention.

If, after reviewing this manual, anything is unclear or technical problems are encountered, contact the dealer from whom you purchased your machine for assistance; and, if there are any additional questions, feel free to contact our Customer Service Department at 800/228-1885. Always have the serial number of your machine available to assist in obtaining the correct information.

II SAFETY ALERT SYMBOL

The symbol shown below is used to call your attention to instructions concerning your personal safety and the safety of others. Watch this symbol. It points out important safety precautions. It means "ATTENTION! Become Alert! Your personal safety is involved!" Read the message that follows and be alert to the risk of personal injury or death.



III PURPOSE OF MANUAL



This instruction manual is intended to familiarize owners with the operation and safety procedures associated with your Cretors oil pumps.



This manual should be kept available to operating and maintenance personnel.



A person who has not read and understood all operating and safety instructions is not qualified to operate the machine.

IV PRODUCT IDENTIFICATION

CRETORS OIL PUMPS:

MODEL	7700 / 7700 RCA-X AUTOMATIC OIL PUMP MODEL
Capacity:	To be used on a 50 lb. Pail of oil
Electrical:	120 Volt, Single Phase, 60 Cycle, 700 Watts, 5.8 amps
Dimensions:	14-1/2" D x 14-1/2" W x 25" H (shipping)
Net Weight:	12 lbs.
Shipping Weight:	20 lbs.

MODEL	7700-SC / 7700SCA-X AUTOMATIC OIL PUMP MODEL
Capacity:	To be used on a 50 lb. Pail of oil
Electrical:	120 Volt, Single Phase, 60 Cycle, 700 Watts, 5.8 amps
Dimensions:	14-1/2" D x 14-1/2" W x 25" H (shipping)
Net Weight:	12 lbs.
Shipping Weight:	20 lbs.

MODEL	7700-E / 7700RCE-X AUTOMATIC OIL PUMP MODEL
Capacity:	To be used on a 50 lb. Pail of oil
Electrical:	230 Volts, 50/60 cycle, single phase, 700 Watts, 3.1 amps
Dimensions:	14-1/2" D x 14-1/2" W x 25" H (shipping)
Net Weight:	12 lbs.
Shipping Weight:	20 lbs.

MODEL	7700-SC-E / 7700SCE-X AUTOMATIC OIL PUMP MODEL
Capacity:	To be used on a 50 lb. Pail of oil
Electrical:	230 Volts, 50/60 cycle, single phase, 700 Watts, 3.1 amps
Dimensions:	14-1/2" D x 14-1/2" W x 25" H (shipping)
Net Weight:	12 lbs.
Shipping Weight:	20 lbs.

MODEL **7700-L / 7700SSA-X AUTOMATIC LOGIC /
SALT/SUGAR OIL PUMP MODEL**

Capacity: To be used on a 50 lb. Pail of oil
 Electrical: 120 Volt, Single Phase, 60 Cycle, 700 Watts, 5.8 amps
 Dimensions: 14-1/2"D x 14-1/2"W x 25"H (shipping)
 Net Weight: 12 lbs.
 Shipping Weight: 20 lbs.

MODEL **7700-E-L / 7700SSE-X AUTOMATIC LOGIC /
SALT/SUGAR OIL PUMP MODEL**

Capacity: To be used on a 50 lb. Pail of oil
 Electrical: 230 Volts, 50/60 cycle, single phase, 700 Watts, 3.1 amps
 Dimensions: 14-1/2"D x 14-1/2"W x 25"H (shipping)
 Net Weight: 12 lbs.
 Shipping Weight: 20 lbs.



7700 Pail Oil Pump



Part Number	Voltage	Wattage	NEMA Plug
**7700XXX-X	120v (60Hz); 230v (50Hz)	700	

Shipping Weight: 20 lbs/ Shipping Dimensions: 25in x 15in x 15in
 Metric Shipping Weight: 9 kg/ Shipping Dimensions: 64cm x 39cm x 39cm
**Actual dimensions available in technical drawing below*
***Actual part number dependant on machine features*

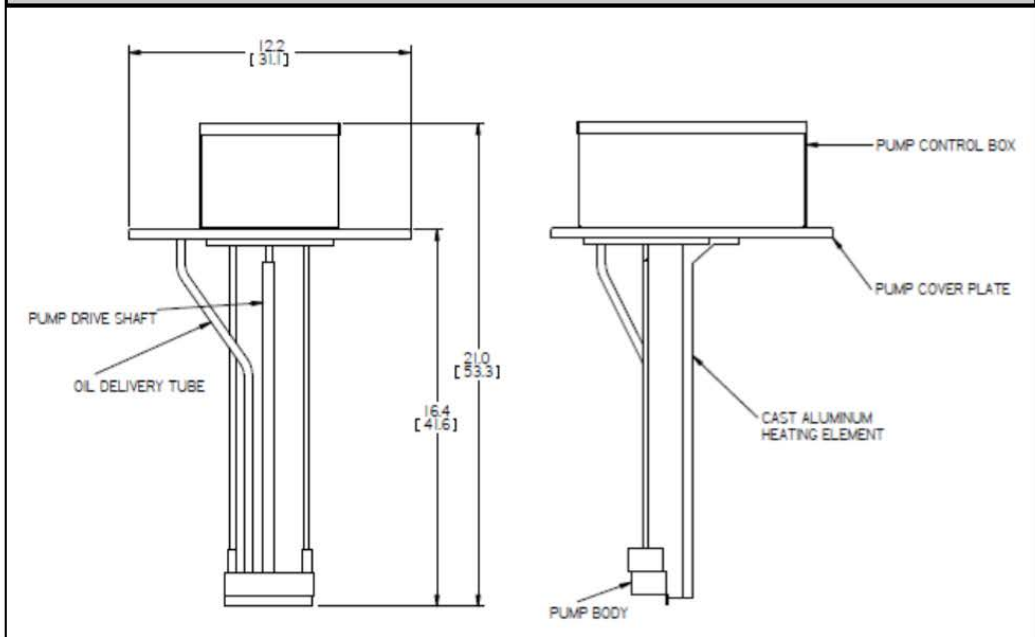

PRINCIPLES OF POPCORN MACHINE OPERATION

Theory and Observations of Popcorn Machine Operation

1. The efficient production of popcorn requires the presence of popcorn kernels, heat, and oil. The purpose of the oil is to distribute the heat throughout kernels evenly and quickly. If the heat is not distributed evenly and quickly, the kernels may burn instead of pop.



2. In order to pop corn in oil, the kettle, oil and parts near the heating elements are necessarily and unavoidably heated to temperatures high enough to pop popcorn. The temperature is controlled using a thermostat located inside the kettle to maintain the kettle at an operating temperature between 380-420°F.

Contact with these surfaces will burn and scald you. Do not touch the kettle, oil or parts in the direct vicinity of the heating elements.

3. The kettle is provided with an agitator to assist in the quick and even distribution of heat throughout the kernels.



4. The oil is heated to high temperatures in a kettle provided with electric heating elements to reach proper popping temperature. An operator is required in the vicinity of the kettle only when handling corn or dumping popped corn from the kettle. Neither of these operations requires direct contact with the kettle. Direct contact with the hot oil, kettle, or heating elements could result in serious burns or scalds. Keep away from the kettle whenever possible. Use the handle when dumping the kettle, and use the provided cups when necessary to measure corn, oil and salt.

5. As the popcorn pops, it will push the lid open and discharge into the cabinet. When the corn finishes popping, the corn remaining in the kettle can be removed by holding the kettle handle in your right hand and rotating down in a clockwise direction to dump the kettle.
6. Your 7700 model Cretors oil pump, which when properly adjusted, automatically delivers the proper amount of oil to the popping kettle.
7. A Cretors Hot rod is available to assist in the melting of solidified oil.

VI CONTROL SWITCH

Time Heat Switch	-turns on the heat element
Indicator light	-indicates operation of the heat element
Push button	-activates timer and motor to dispense oil
Power switch	-turns on the power to oil pump on self-contained unit

VII INSTALLATION INSTRUCTIONS

A. Location

Choose a location for your Cretors oil pump to maximize the ease of operation and maintenance procedures. Check your local building and fire codes for location restrictions.

B. Power Supply

Determine the required power supply.



Connect your dispenser only to the correct power source. Failure to do so may result in personal injury or death and may damage your machine.



C. Cretors & Co. recommends dedicated circuits for popcorn machines. The 7700-SC model pump requires a 15 amp circuit. Check your local electrical codes regarding cut-off requirements.



Make certain your popcorn machine and oil pump is properly grounded. Failure to do so may result in damage to your equipment or present a shock hazard.

C. Connecting oil pump to power source



Make certain that power supply circuit breakers are in the off position. Make certain all switches on the machine are in the off position before plugging in your 7700 model Cretors oil pumps.



Perform work only on de-energized circuits. Failure to do so may lead to electrical shock resulting in personal injury or death.

- D. Plug your machine and oil pump into the correct type of outlet, turn on the circuit breaker and then turn on the machine switches. If the motor groans, the receptacle in the 8 108 485 115 been improperly wired. Contact an Electrician.

Make certain all switches are in the off position before plugging in your Cretors popcorn machine and oil pump.

E. Pump Installation

Cretors oil pump and Hot Rod are intended for use in standard steel pails only. The following instructions assume the presence of a Deluxe or Economy base.

1. Make certain the pump switch on the control panel is in the OFF position.
2. Inserting the pump into the pail
Place the pump on top of the oil and center in the pail. If the oil is solid, the pump can be rotated clockwise/counterclockwise 90°, and the metal “blade” on the bottom of the pump will cut into the hard oil. Connect the power supply cord to the pump. The special connector will only plug in one way and it may be necessary to rotate it in order to insert it completely.

Turn on the auxiliary and pump switches and set the time heat switch to 20 or 30 minutes and allow the pump to melt itself into the oil. Proceed to step 3.



Do not overheat the oil in the pail. Once the oil is liquefied, it is not necessary to continue heating the oil. If the heat timer is continually restarted, the oil will become too hot and damage the oil tubing, becoming a source of leaks, and the hot pail a source of burns.



If any oil should spill or leak, be sure to promptly and thoroughly clean the exposed area. Failure to do so may result in a slipping hazard resulting in serious injury or death.

3. Connect the pump to the oil delivery tube by pushing the quick connect socket at the end of the delivery hose, onto the quick disconnect plug mounted on the support cover. When the plug is fully inserted, the spring will snap into place and hold the connector securely.
4. Make certain the oil delivery hose contains no low spots. Oil may solidify in such low spots and clog the hose.

F. Pump Adjustment



Make sure that the popper heat switch is off during pump adjustments. This is to avoid touching a hot kettle, which may result in serious burns.

1. To check the output adjustment, place the kettle in the dump position and hold the oil measure cup under the oil delivery tube.



Never hold the oil measure cup under the oil delivery tube if the kettle is hot. This may result in serious burns or injuries.

2. Press the delivery button and wait for the pump to cycle. Dispose of the oil, and cycle the pump again. To obtain accurate readings, let the oil drain back to the pail as it would between popping. Observe the oil in the tube to confirm that the oil has drained back to the pail.

3. After three cycles, the amount of delivered will be consistent. Check this amount with the measuring cup. Below is a good starting point to set the timer for an approximate amount of oil to be delivered. Each machine may vary.

<u>MACHINES</u>	<u>AMOUNT OF OIL</u>	<u>SET TIMER TO "X" SECONDS</u>
PT14	4.5 oz.	3 seconds
MR16	5.5 oz.	4 seconds
EG20, DI20, PR20	7.5 oz.	5 seconds
EG32, DI32, PR32, GG32	11 oz.	9 seconds
DI48		
EG48, DI48, PR48,	16 oz.	12 seconds
EG60, DI60, GG60	20 oz.	16 seconds

*Recommended pump timer settings. Machines may differ slightly.

4. If the amount of oil is not correct, it may be adjusted. To adjust the pump:
 - a. Turn off the pump switch
 - b. Put the pail step in place
 - c. Disconnect oil hose
 - d. Move pail out of cabinet onto pail step. (Use a slight lifting and pulling motion)



Make sure you brace the pail step against the cabinet to avoid sliding it off the base of the cabinet when pulling the pail across it. Use proper moving techniques to avoid injury to back.

- e. To set the oil quantity delivery:
 - Remove the snap out plug on top of the switch box, which is on the top of the pump, to expose the timer.
 - Check to make sure the timer has good contact by pushing down lightly on timer, making certain not to push any of the switches.
 - Switches 1 through 10 are each assigned a certain amount of seconds of delay time. Each successive switch is double the amount of delay time for the switch before it. The amounts of delay time are written at the top, along the "OPEN"/"OFF" line (i.e. 1,2,4,8, etc).
 - The switch must be in the UP position along the "OPEN"/"OFF" line for the delay time to apply. An example of this for three seconds would have the switch corresponding to the 1 on the "OPEN"/"OFF" line up along with the switch corresponding to the 2 on the "OPEN"/"OFF" line.
 - For Salt/sugar pumps, the oil time is adjusted through the timers located in the popper the same way.
 - For Logic pumps, the oil time is adjusted through the Logic board. Please refer to your machine manual.

To turn the dip switches ON the dip switch needs to be pressed down to the number side opposite of the open side.

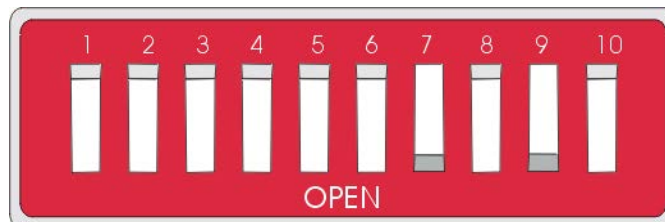

Switch #1 = 1 seconds
#2 = 2 seconds
#3 = 4 seconds
#4 = 8 seconds
#5 = 16 seconds

Example: If you turn #3 and #4 on, the time delay will be 12 seconds.

- f. Install snap out plug (which was removed in first step in section e).



Move pail back into cabinet. Use proper moving techniques to avoid injury to back.

- g. Connect oil hose by snapping in place.

- h. Remove pail step and place in bottom of cabinet for easy access in future.

- i. Turn on the pump switch and re-check the oil output using steps 1 thru 4 in the Pump Adjustment section.

VIII OPERATING INSTRUCTIONS



Do not attempt to operate your Cretors popcorn machine or oil pumps until you have read and understood this manual. Failure to do so may result in serious injury or death.



Do not attempt to operate your Cretors popcorn machine or oil pumps unless the installation instructions have been strictly adhered to. Failure to do so may result in serious injury or death.



Operate your popcorn machine and oil pump only if it is in sanitary condition. Failure to do so may result in illness to your customers.



Always turn off the kettle heat switch when no popping corn. Failure to do so will cause oil to stain the kettle, possibly resulting in an unsanitary condition. It may also cause a “flash” fire if oil is added to a kettle left unattended with the heat on, resulting in serious burns or death.

To operate your Cretors 7700 oil pump:

1. Turn on pump switch



NOTE: Avoid contact with the kettle when adding corn or salt. ALWAYS ADD CORN TO THE KETTLE BEFORE ADDING OIL. FAILURE TO DO SO MAY RESULT IN THE OIL BEING HEATED TOO RAPIDLY RESULTING IN A FIRE.

2. Push the oil pump button which will provide the correct amount of oil based on previously setting and testing the timer.
3. When the oil bucket is empty, insert the oil pump into a new bucket as described in the Installation Section.



Follow the recommended sanitation procedures.

IX TROUBLE SHOOTING AND SERVICE INSTRUCTIONS



In the case of improper operation, qualified personnel only should perform the following diagnostic checks, and, if necessary, corresponding adjustments and repairs. All of the following procedures present an electrical shock hazard and can cause serious injury or death

1. Nothing works:
QUESTION: Is the pump plugged in?
QUESTION: Is the machine plugged in?
2. Pump not heating:
 - a. No indicator light or heat - check heat timer
 - b. Indicator light, but no heat - check element
3. Heat will not go off:
Bad heat timer - replace.
4. Motor hums, but will not turn:
 - a. Hard oil - melt oil
 - b. Drive shaft does not turn freely - may have been dropped on element causing discharge tube to jam into pump gears - clear jam
 - c. Motor bad - replace
5. Pump runs all the time:
 - a. Timer set incorrectly - rest (See Pump Adjustment)

- b. Bad timer - replace
6. Solid oil in pail:
Melt the oil in the pail by turning the time heat switch (2012) on the pump. For Logic, press "Oil Heat" button on Logic board. Make sure Logic is set for 7700 Pump.
 7. Motor runs, but does not dispense oil:
 - a. Check for oil in the pail - refill
 - b. Discharge tube (2566) pulled out of pump body
 - c. Solid oil in line - the oil in the tube may be melted with a rag soaked in hot water and wrapped around tube. A hair dryer may also be used to heat the tube

X SANITATION INSTRUCTIONS



Be certain the machine is turned 'OFF' and power is unplugged before sanitizing this machine unless a specific cleaning procedure requires power to the machine. Failure to do so could result in injury or death.



Do not clean heated surfaces until they have been given sufficient time to cool. Failure to do so may result in serious burns or scalds.

The pump is most easily cleaned by using two empty popping oil pails or buckets that have been thoroughly cleaned of oil. The cleaning procedure is:

1. Fill one pail $\frac{1}{2}$ full of hot water and mix in $\frac{1}{2}$ package of CKC (Cretors Kettle Cleaner).
2. Put the pump on the pail and turn on the heat timer to 20 minutes and leave until the water is hot.
3. Unplug the pump and hold the pump over the pail. Clean the outside of the pump and heating element. Do not immerse the pump motor or get the top plate and motor wet. Put the pump on the pail again, and reconnect the electrical power supply and oil line.
4. Put the kettle in the dump position, and place a container under the oil discharge tube to catch the cleaning water.
5. Cycle the pump several times catching the cleaning water in the empty container.
6. Disconnect the pump. Take the pump to a sink and thoroughly rinse the pump and heat element.



Do not get the top of the pump wet. Electrical shorts and a shock hazard, which can cause injury, from the result of the wires inside the top of the pump getting wet.

7. Take a second pail and fill it with clean water. If only one pail is available, empty the soapy water from the pail, rinse it completely and fill it with clean water.

8. Reconnect the pump, and cycle it several times to thoroughly rinse the inside of the pump and oil lines.
9. Allow the pump and oil lines to drain.
10. After draining pump and oil lines, reconnect the pump and cycle oil once to prevent rust in the pump.

This manual is filled with timesaving and money-saving information regarding your Cretors popcorn machine. There is nothing, however, more important than the safety aids and warnings found throughout this document.

If you have any questions, feel free to contact our Customer Service at 800/228-1885.

Additional copies of this manual can be obtained from Customer Service.

Cretors warrants this machine to be free of defects in parts, materials and workmanship for two years. Please fill out and return the registration card to activate your warranty. If you have questions concerning the warranty, please contact Customer Service at 800/228-1885.

7700 REMOTE PUMP -120V
 BEGINNING SERIAL # 99021307

DOC: 77300001

7700-A-1.0-A
 08/01

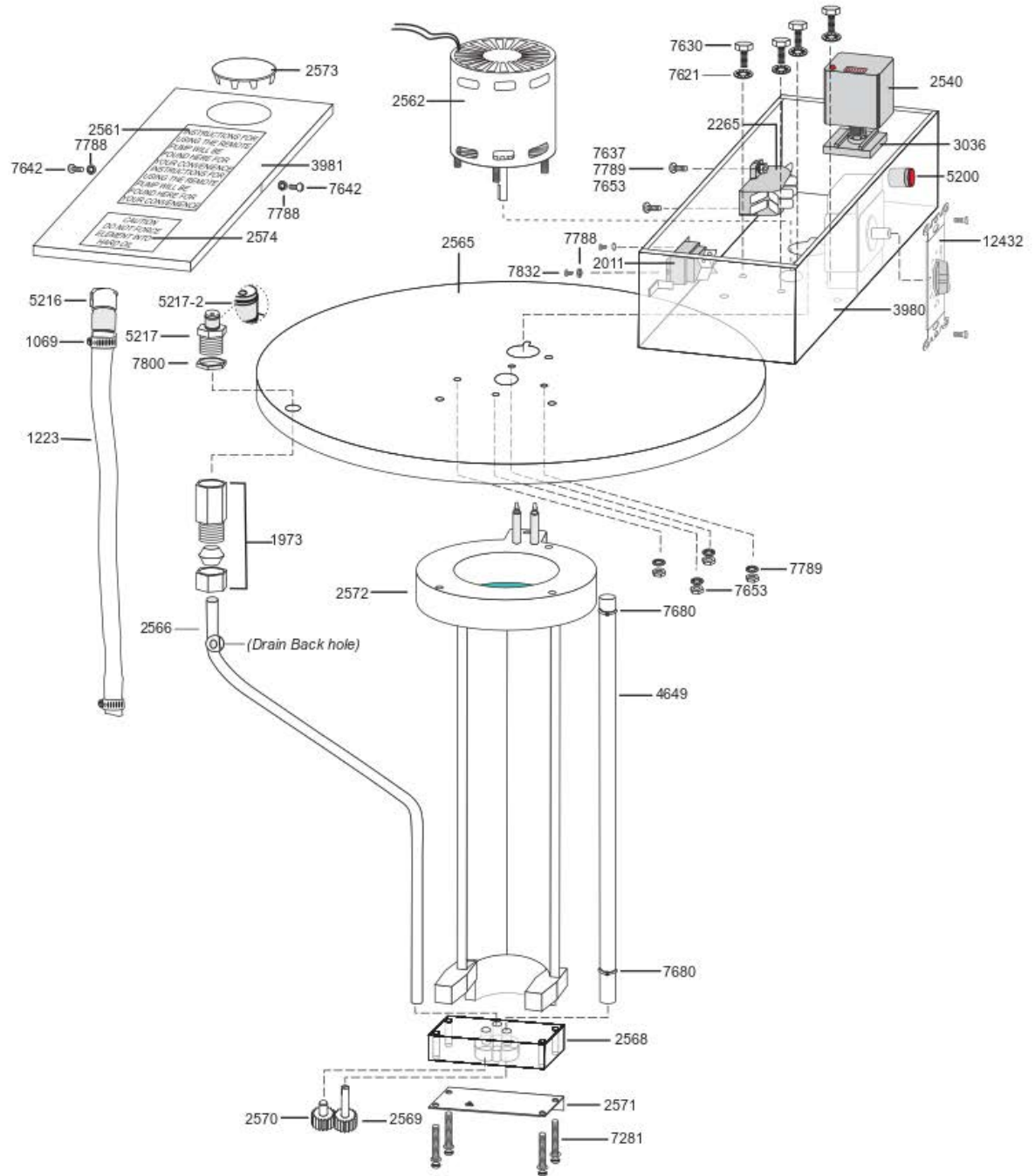

C. CRETORS AND COMPANY

7700 REMOTE PUMP -120V
 BEGINNING SERIAL # 99021307

DOC: 77300001

7700-A-1.0-A
08/01

1069	CLAMP - HOSE	7800	1/4" NPT HEX THIN NUT
1223	TUBING - NALGENE SOLD PER FOOT	7832	8-32 x 1/4 BINDING HEAD
1973	1/4" NPT TO 3/8" TUBE SS	12432	SWITCH - TIME HEAT
2011	PUMP RECEPTACLE		
2540	TIMER PLUG IN - 120V		
2265	TERMINAL BLOCK-2 PIN		
2561	DECAL -PUMP INSTRUCTIONS		
2562	PUMP MOTOR - 120V		
2562-C	PUMP MOTOR - 230V		
2565	PUMP SUPPORT COVER		
2566	OIL INLET TUBE		
2568	PUMP BODY		
2569	PUMP DRIVE GEAR (LONG)		
2570	PUMP IDLER GEAR (SHORT)		
2571	PUMP BODY COVER		
2572	PUMP HEAT ELEMENT - 120V		
2573	HOLE COVER W/ "O" RING		
2574	CAUTION-DECAL		
3036	RELAY BASE - 8PIN		
3980	PUMP BOX - 120V		
3981	PUMP BOX COVER 120V		
4649	PUMP SHAFT		
5200	INDICATOR LIGHT		
5216	QUICK CONNECT SOCKET		
5217	QUICK DISCONNECT PLUG		
5217-2	"O" RING ONLY		
7281	8-32 x 1-1/2 THUMB SCREW		
7621	1/4 INTERNAL TOOTH LOCKWASHER		
7630	1/4 x 20 x 1/2 HEX BOLT		
7637	8-32 x 1/2 SS TRUSS HEAD		
7642	8-32 x 3/8 SS TRUSS HEAD		
7653	8-32 HEX NUT		
7680	1/8 x 3/4 'T' COTTER PIN		
7788	#6 LOCKWASHER		
7789	#8 STARLOCKWASHER		

 C. CRETORS AND COMPANY

7700 REMOTE PUMP SELF CONTAINED - 230V
 BEGINNING SERIAL No. 99043442

DOC: 77300003

7700-SC-E-1.0-A
 03/2000

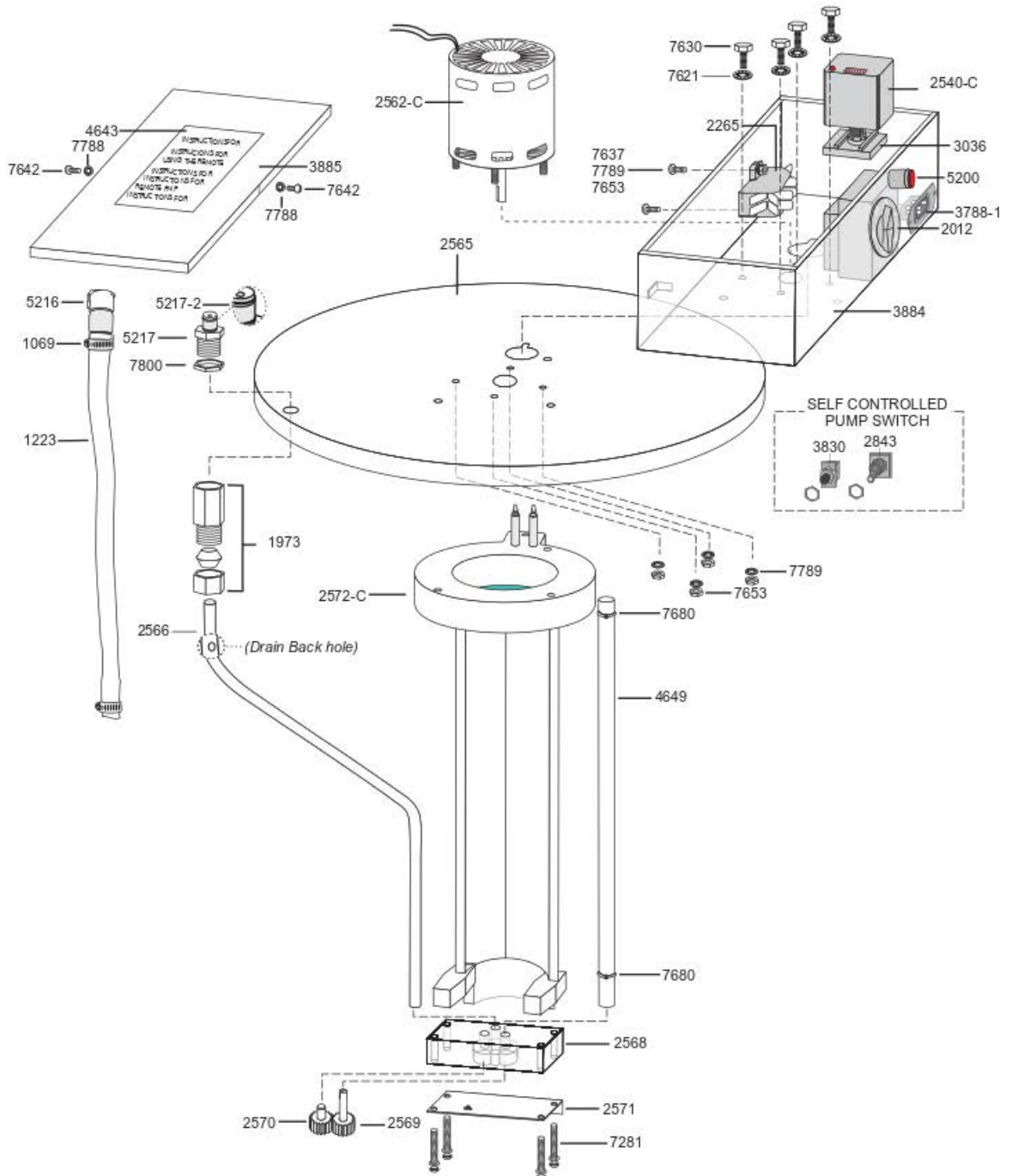

C. CRETORS AND COMPANY

7700 REMOTE PUMP SELF CONTAINED - 230V
 BEGINNING SERIAL No. 99043442

DOC: 77300003

7700-SC-E-1.0-A
 03/2000

1069	CLAMP - HOSE	7788	#6 LOCKWASHER
1223	TUBING - NALGENE SOLD PER FOOT	7800	1/4" NPT HEX THIN NUT
1973	1/4" NPT TO 3/8" TUBE SS		
2012	SWITCH - TIME HEAT		
2265	TERMINAL BLOCK-2 PIN		
2540-C	TIMER PLUG IN - 230V		
2562-C	PUMP MOTOR - 230V		
2565	PUMP SUPPORT COVER		
2566	OIL INLET TUBE		
2568	PUMP BODY		
2569	PUMP DRIVE GEAR (LONG)		
2570	PUMP IDLER GEAR (SHORT)		
2571	PUMP BODY COVER		
2572-C	PUMP HEAT ELEMENT - 240V		
2573	HOLE COVER W/ "O" RING		
2843	SWITCH-DOUBLE POLE		
3036	RELAY BASE - 8PIN		
3788-1	IEC 320 POER INLET - SCREW MOUNT		
3827	RECEPTACLE ASSY - 230V PUMP		
3830	SWITCH-PUSH BUTTON		
3885	PUMP BOX COVER 230V		
3884	PUMP BOX - 230V SC		
4643	DECAL - PUMP INSTRUCTIONS-INTL		
4649	PUMP SHAFT		
5200	INDICATOR LIGHT		
5216	QUICK CONNECT SOCKET		
5217	QUICK DISCONNECT PLUG		
5217-2	"O" RING ONLY		
7281	8-32 x 1-1/2 THUMB SCREW		
7621	1/4 INTERNAL TOOTH LOCKWASHER		
7630	1/4 x 20 x 1/2 HEX BOLT		
7637	8-32 x 1/2 SS TRUSS HEAD		
7642	8-32 x 3/8 SS TRUSS HEAD		
7653	8-32 HEX NUT		
7680	1/8 x 3/4 "T" COTTER PIN		

C. CRETORS AND COMPANY

7700 REMOTE PUMP SELF CONTAINED - 230V - SHORT
 BEGINNING SERIAL No. 0305

DOC: 77300004

7700S-SC-E-1.0-A
 05/2003

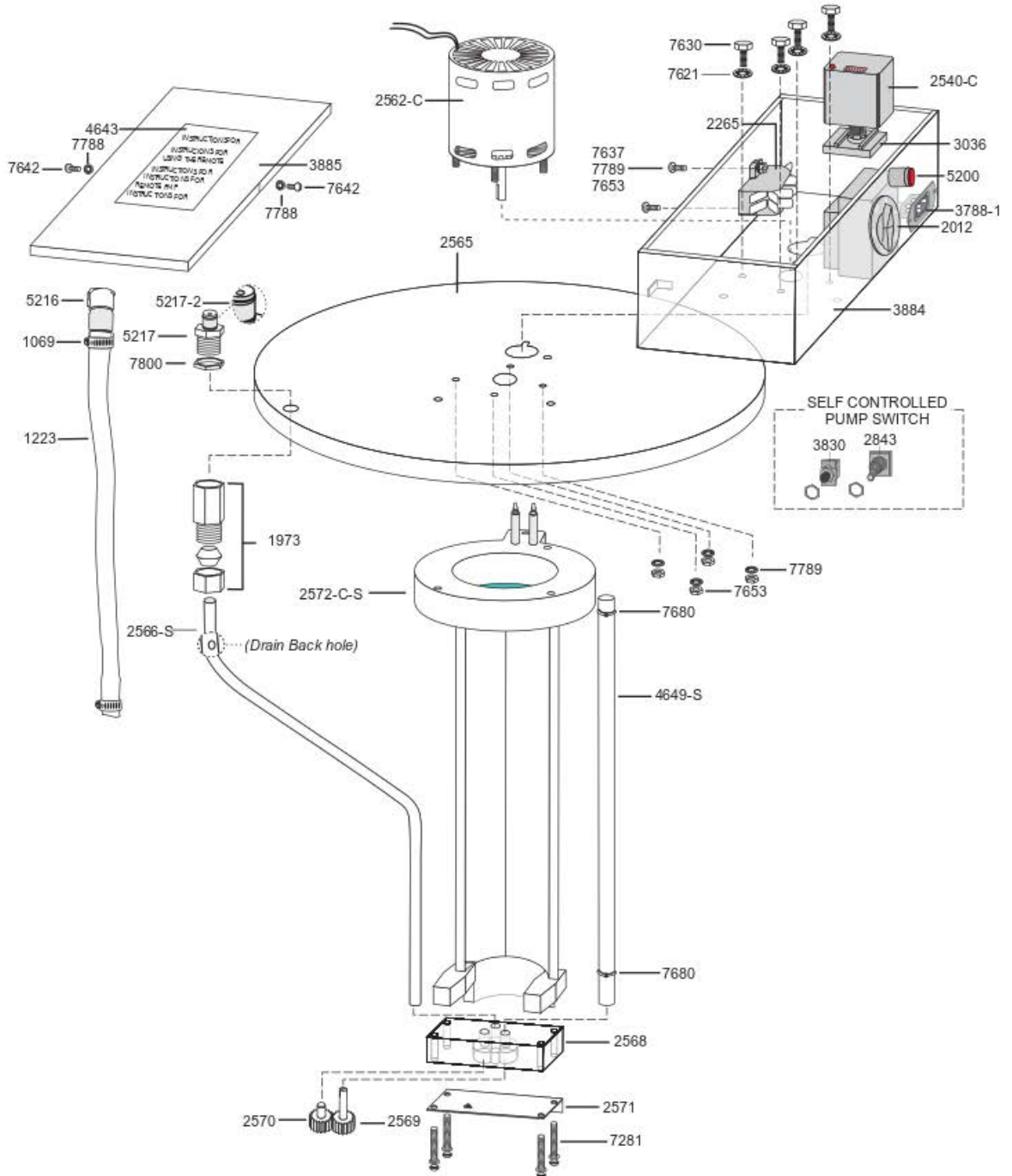

C. CRETORS AND COMPANY

7700 REMOTE PUMP SELF CONTAINED - 230V - SHORT DOC: 77300004 7700S-SC-E-1.0-A
 BEGINNING SERIAL No. 0305 05/2003

1069	CLAMP - HOSE	7788	#6 LOCKWASHER
1223	TUBING - NALGENE SOLD PER FOOT	7800	1/4" NPT HEX THIN NUT
1973	1/4" NPT TO 3/8" TUBE SS		
2012	SWITCH - TIME HEAT		
2265	TERMINAL BLOCK-2 PIN		
2540-C	TIMER PLUG IN - 230V		
2562-C	PUMP MOTOR - 230V		
2565	PUMP SUPPORT COVER		
2566-S	OIL INLET TUBE		
2568	PUMP BODY		
2569	PUMP DRIVE GEAR (LONG)		
2570	PUMP IDLER GEAR (SHORT)		
2571	PUMP BODY COVER		
2572-C-S	PUMP HEAT ELEMENT - 240V		
2573	HOLE COVER W/ "O" RING		
2843	SWITCH-DOUBLE POLE		
3036	RELAY BASE - 8PIN		
3788-1	IEC 320 POER INLET - SCREW MOUNT		
3827	RECEPTACLE ASSY - 230V PUMP		
3830	SWITCH-PUSH BUTTON		
3885	PUMP BOX COVER 230V		
3884	PUMP BOX - 230V SC		
4643	DECAL - PUMP INSTRUCTIONS-INTL		
4649-S	PUMP SHAFT		
5200	INDICATOR LIGHT		
5216	QUICK CONNECT SOCKET		
5217	QUICK DISCONNECT PLUG		
5217-2	"O" RING ONLY		
7281	8-32 x 1-1/2 THUMB SCREW		
7621	1/4 INTERNAL TOOTH LOCKWASHER		
7630	1/4 x 20 x 1/2 HEX BOLT		
7637	8-32 x 1/2 SS TRUSS HEAD		
7642	8-32 x 3/8 SS TRUSS HEAD		
7653	8-32 HEX NUT		
7680	1/8 x 3/4 T COTTER PIN		

C. CRETORS AND COMPANY

7700 REMOTE PUMP SELF CONTAINED - 120V - SHORT
 BEGINNING SERIAL No. 0305

DOC: 77300005

7700S-SC-A-1.0-A
 05/2003

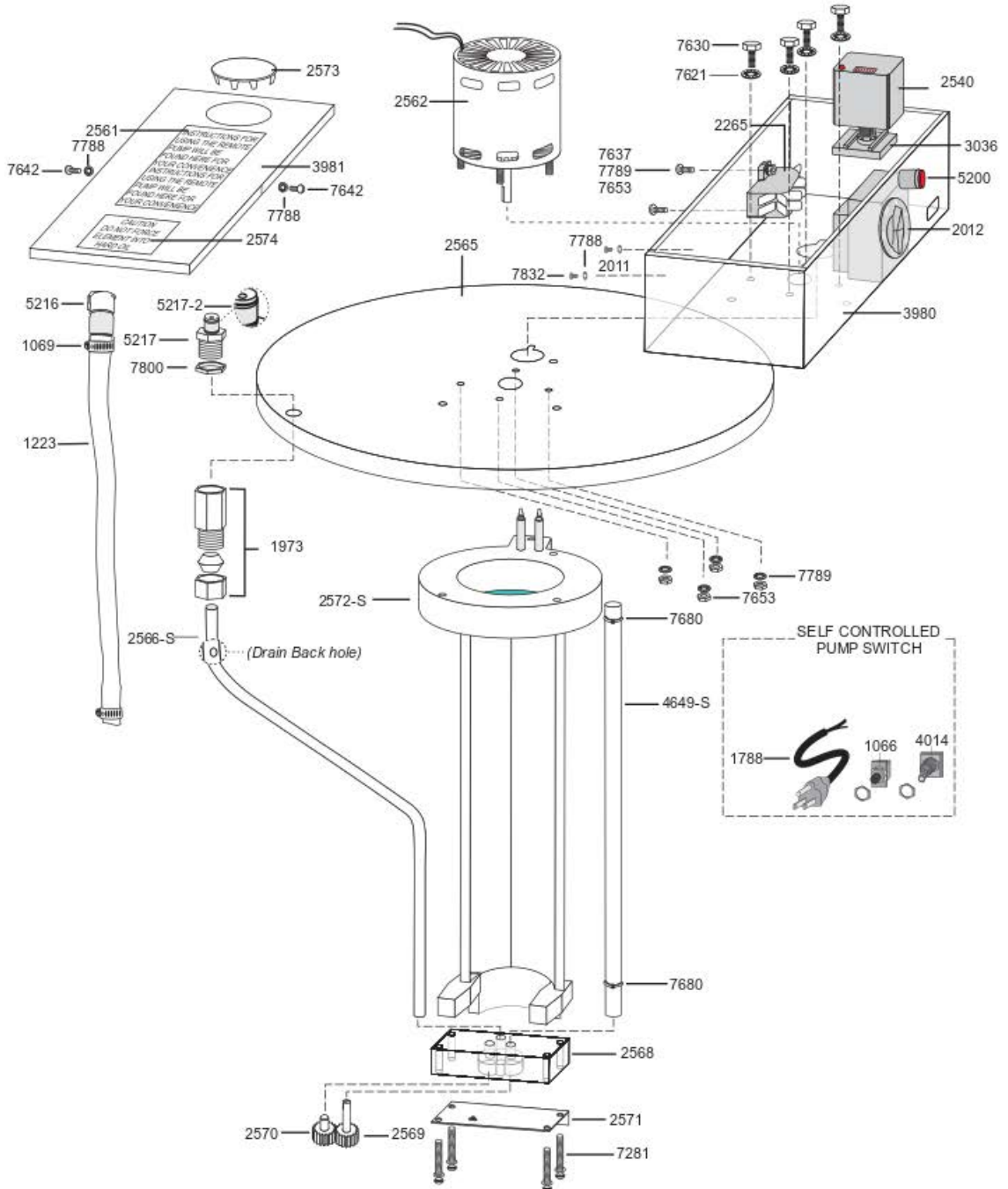

C. CRETORS AND COMPANY

7700 REMOTE PUMP SELF CONTAINED - 120V - SHORT
 BEGINNING SERIAL No. 0305

DOC: 77300005

7700S-SC-A-1.0-A
 05/2003

1069	CLAMP - HOSE	1255	CONNECTOR 3/8"
1223	TUBING - NALGENE SOLD PER FOOT	1788	CORD 10 AMP, 16-3,NEMA 5-15P
1973	1/4" NPT TO 3/8" TUBE SS	1881	DECAL - PUMP DELIVER ON-OFF
2011	PUMP RECEPTACLE	2105	SWITCH PLATE - SC PUMP 120V
2012	SWITCH - TIME HEAT	4014	SWITCH (SPST, 20A, 120V)
2265	TERMINAL BLOCK-2 PIN		
2540	TIMER PLUG IN - 230V		
2562	PUMP MOTOR - 120V		
2565	PUMP SUPPORT COVER		
2566-S	OIL INLET TUBE		
2568	PUMP BODY		
2569	PUMP DRIVE GEAR (LONG)		
2570	PUMP IDLER GEAR (SHORT)		
2571	PUMP BODY COVER		
2572-S	PUMP HEAT ELEMENT - 120V		
2573	HOLE COVER W/ "O" RING		
3036	RELAY BASE - 8PIN		
3981	PUMP BOX COVER 120V		
3980	PUMP BOX - 120V SC		
4649-S	PUMP SHAFT		
5200	INDICATOR LIGHT		
5216	QUICK CONNECT SOCKET		
5217	QUICK DISCONNECT PLUG		
5217-2	"O" RING ONLY		
7281	8-32 x 1-1/2 THUMB SCREW		
7621	1/4 INTERNAL TOOTH LOCKWASHER		
7630	1/4 x 20 x 1/2 HEX BOLT		
7637	8-32 x 1/2 SS TRUSS HEAD		
7642	8-32 x 3/8 SS TRUSS HEAD		
7653	8-32 HEX NUT		
7680	1/8 x 3/4 T' COTTER PIN		
7788	#6 LOCKWASHER		
7800	1/4" NPT HEX THIN NUT		
7572-A	SELF CONTAINED PUMP PARTS - 120V		
1066	SWITCH - PUSH BUTTON		

C. CRETORS AND COMPANY

7700 REMOTE PUMP - 230V
 BEGINNING SERIAL # 01037830

DOC: 77300005

7700-A-1.0-A
 08/01

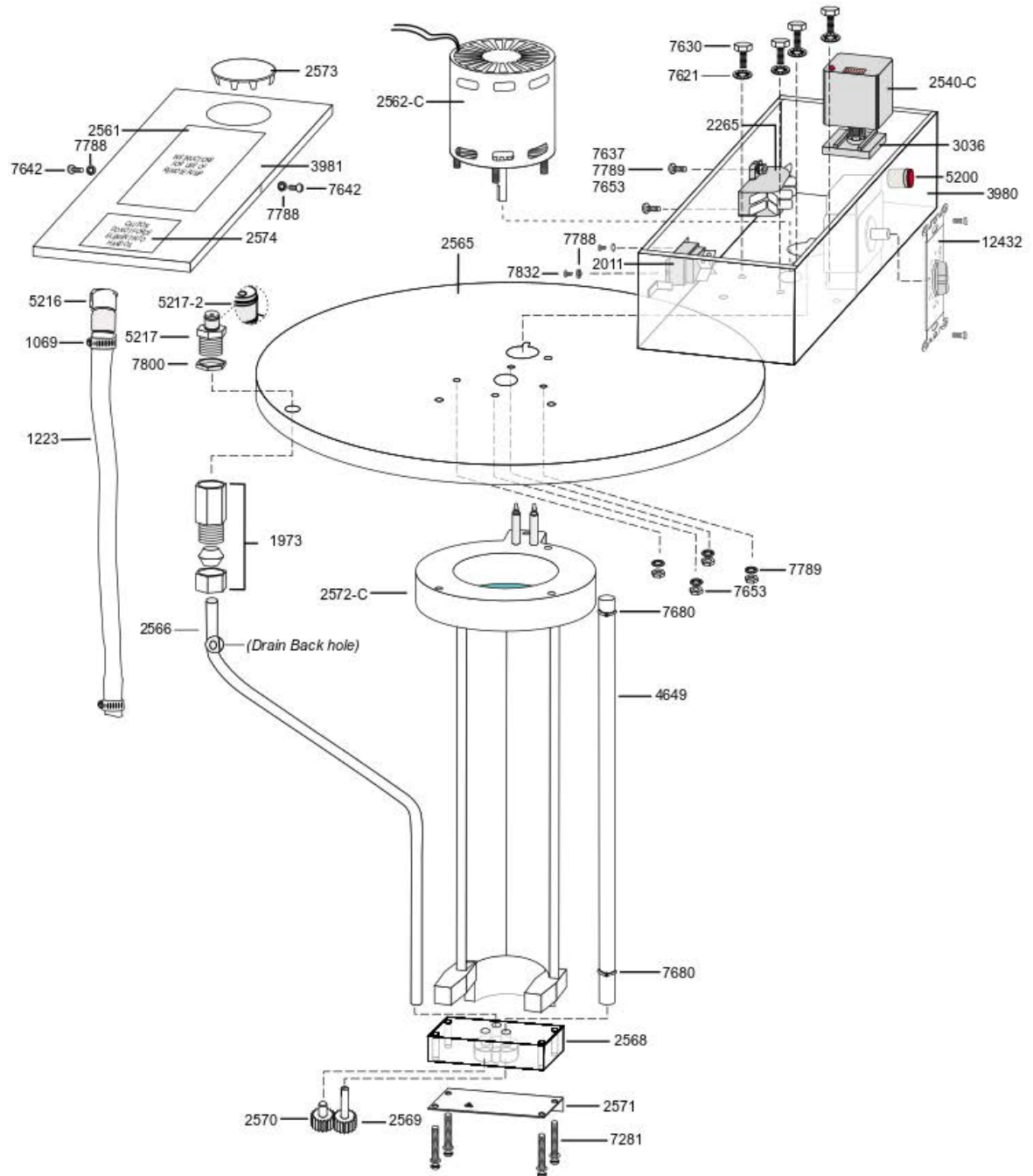

C. CRETORS AND COMPANY

7700 REMOTE PUMP - 230V
 BEGINNING SERIAL # 01037830

DOC: 77300005

7700-A-1.0-A
 08/01

1069	CLAMP - HOSE	7800	1/4" NPT HEX THIN NUT
1223	TUBING - NALGENE SOLD PER FOOT	7832	8-32 x 1/4 BINDING HEAD
1973	1/4" NPT TO 3/8" TUBE SS	12432	TIMER - SPRING WOUND
2011	PUMP RECEPTACLE		
2540	TIMER-PLUG IN - 230V		
2265	TERMINAL BLOCK-2 PIN		
2561	DECAL -PUMP INSTRUCTIONS		
2562	PUMP MOTOR - 230V		
2562-C	PUMP MOTOR - 230V		
2565	PUMP SUPPORT COVER		
2566	OIL INLET TUBE		
2568	PUMP BODY		
2569	PUMP DRIVE GEAR (LONG)		
2570	PUMP IDLER GEAR (SHORT)		
2571	PUMP BODY COVER		
2572	PUMP HEAT ELEMENT - 240V		
2573	HOLE COVER W/ "O" RING		
2574	CAUTION-DECAL		
3036	RELAY BASE - 8PIN		
3980	PUMP BOX - 120V		
3981	PUMP BOX COVER 120V		
4649	PUMP SHAFT		
5200	INDICATOR LIGHT		
5216	QUICK CONNECT SOCKET		
5217	QUICK DISCONNECT PLUG		
5217-2	"O" RING ONLY		
7281	8-32 x 1-1/2 THUMB SCREW		
7621	1/4 INTERNAL TOOTH LOCKWASHER		
7630	1/4 x 20 x 1/2 HEX BOLT		
7637	8-32 x 1/2 SS TRUSS HEAD		
7642	8-32 x 3/8 SS TRUSS HEAD		
7653	8-32 HEX NUT		
7680	1/8 x 3/4 'T' COTTER PIN		
7788	#6 LOCKWASHER		
7789	#8 STARLOCKWASHER		

7700 REMOTE CONTROL PUMP
 WIRING DIAGRAM - 100/120V - 50/60 Hz
 BEGINING SERIAL NO. 1903

DOC: 7700Ar1

03/2019

MACHINE CIRCUIT

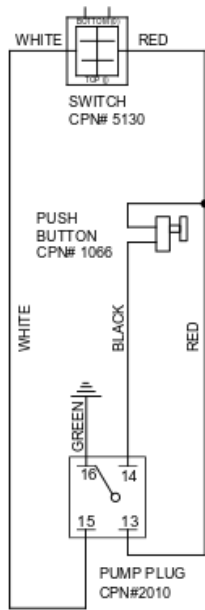

PUMP CIRCUIT

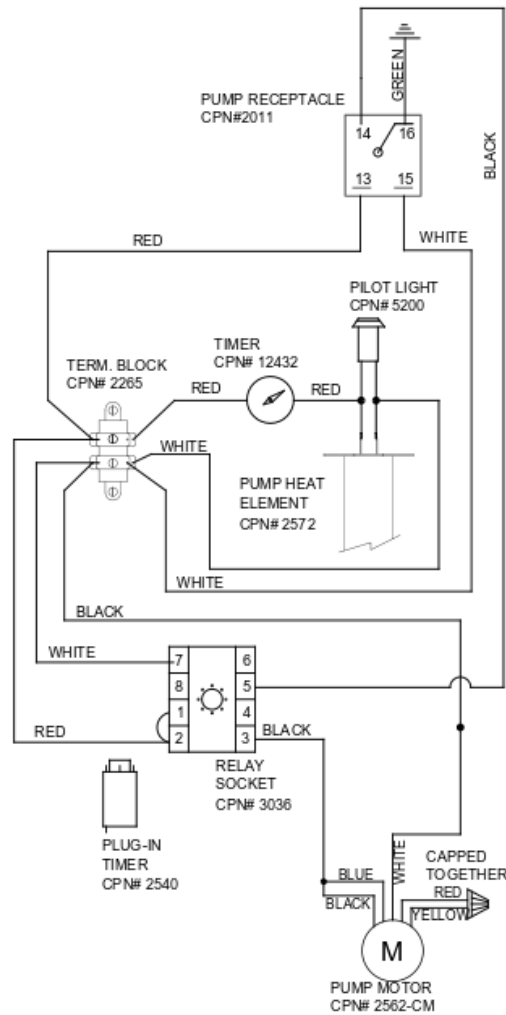

C.CRETORS AND COMPANY
 170 MITTLE DRIVE
 WOOD DALE, ILLINOIS 60191
 PHONE(847)616-6900, (800)228-1885, FAX (847)616-6970
 WEB SITE: <http://www.cretors.com> Email: postmaster@cretors.com

DOC: 7700Ar1

7700 REMOTE CONTROL PUMP - SALT/SUGAR
 WIRING DIAGRAM - 100V-120V 60Hz.
 BEGINING SERIAL NO. 1705

DOC: 7700ASSRCr2

05/2017

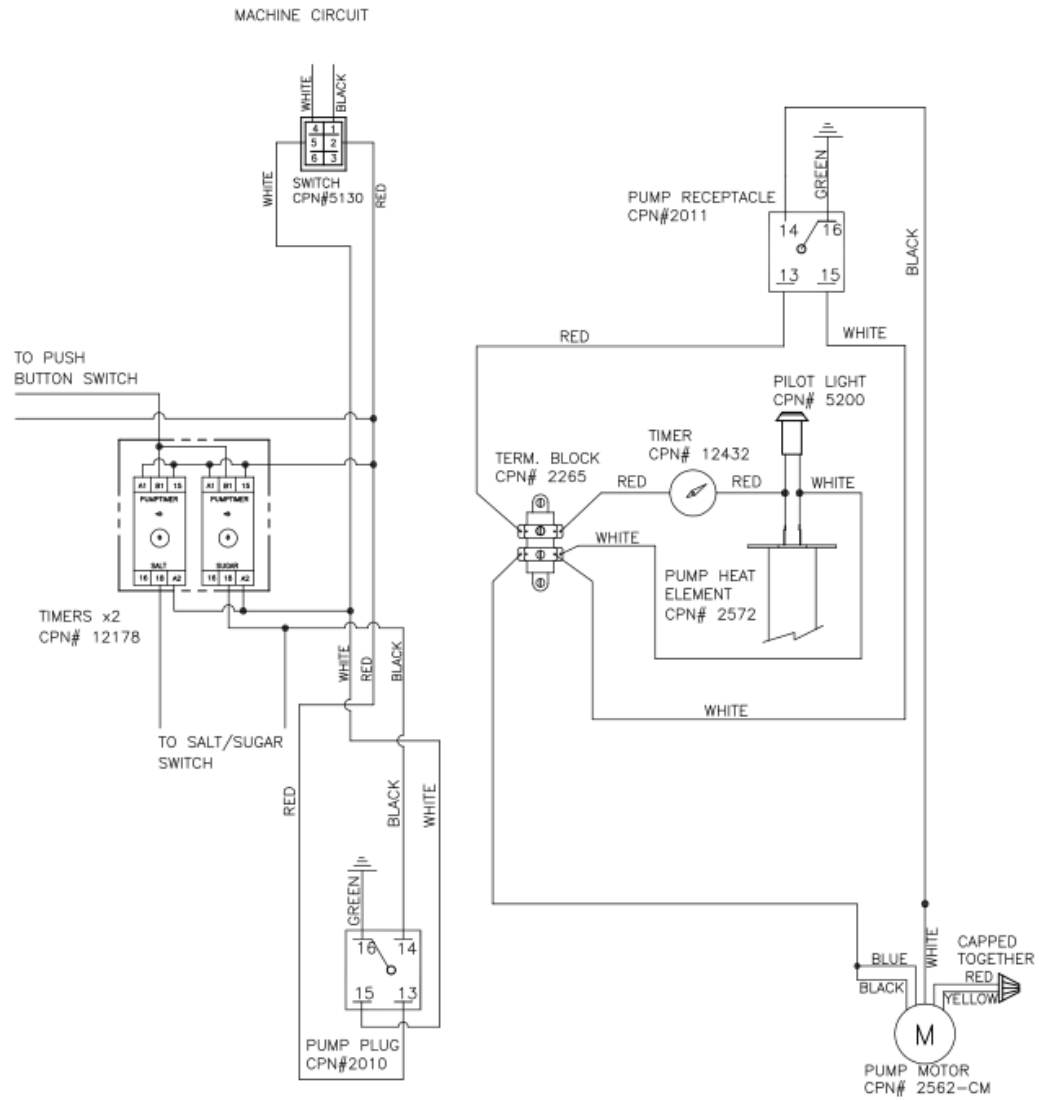

C.CRETORS AND COMPANY
 170 MITTEL DRIVE
 WOOD DALE, ILLINOIS 60191
 PHONE(847)616-6900, (800)228-1885, FAX (847)616-6970
 WEB SITE: <http://www.cretors.com> Email: postmaster@cretors.com

7700 REMOTE CONTROL PUMP
 WIRING DIAGRAM - 230V 50Hz
 BEGINING SERIAL NO. 1903

DOC: 7700Er1

03/2019

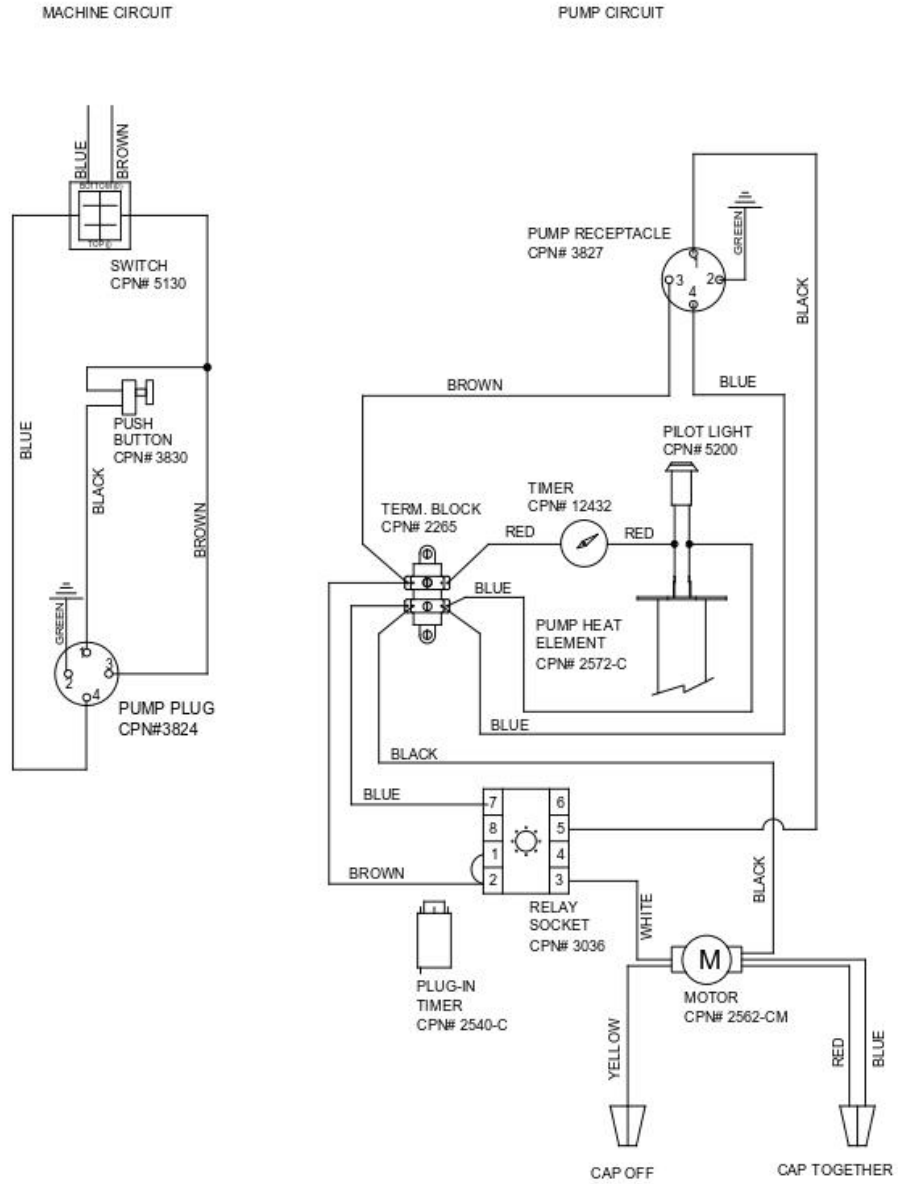

C.CRETORS AND COMPANY
 170 MITTLE DRIVE
 WOOD DALE, ILLINOIS 60191
 PHONE(847)616-6900, (800)228-1885, FAX (847)616-6970
 WEB SITE: <http://www.cretors.com> Email: postmaster@cretors.com

DOC: 7700Er1

7700 SELF CONTAINED PUMP
 WIRING DIAGRAM - 220V 50Hz.
 BEGINING SERIAL NO. 1705

DOC: 7700ESCr3

05/2017

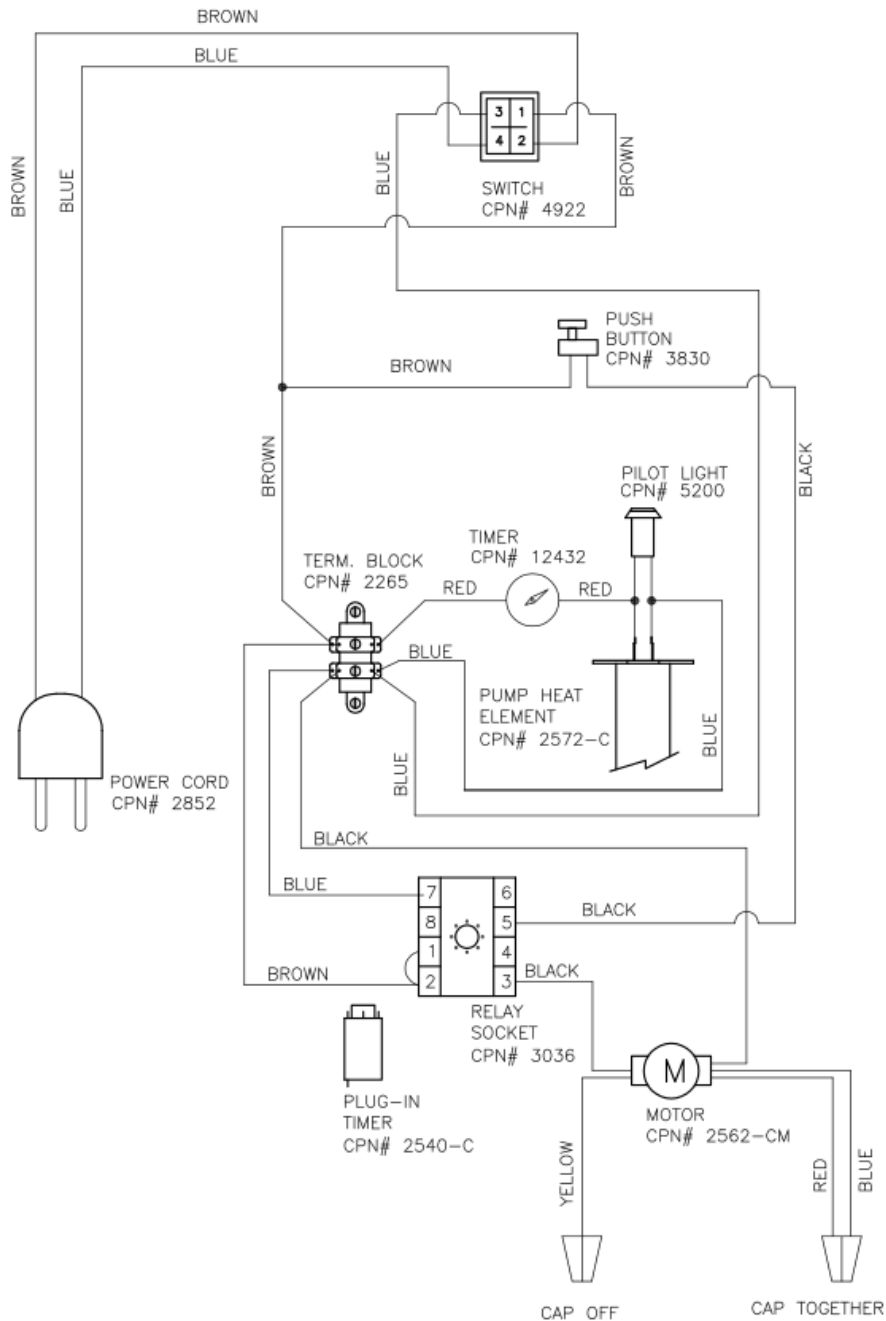

C.CRETORS AND COMPANY
 170 MITTEL DRIVE
 WOOD DALE, ILLINOIS 60191
 PHONE(847)616-6900, (800)228-1885, FAX (847)616-6970
 WEB SITE: <http://www.cretors.com> Email: postmaster@cretors.com

7700 REMOTE CONTROL PUMP SALT/SUGAR
 WIRING DIAGRAM - 230V 50Hz
 BEGINING SERIAL NO. 1507

DOC: 7700ESSr2

07/2015

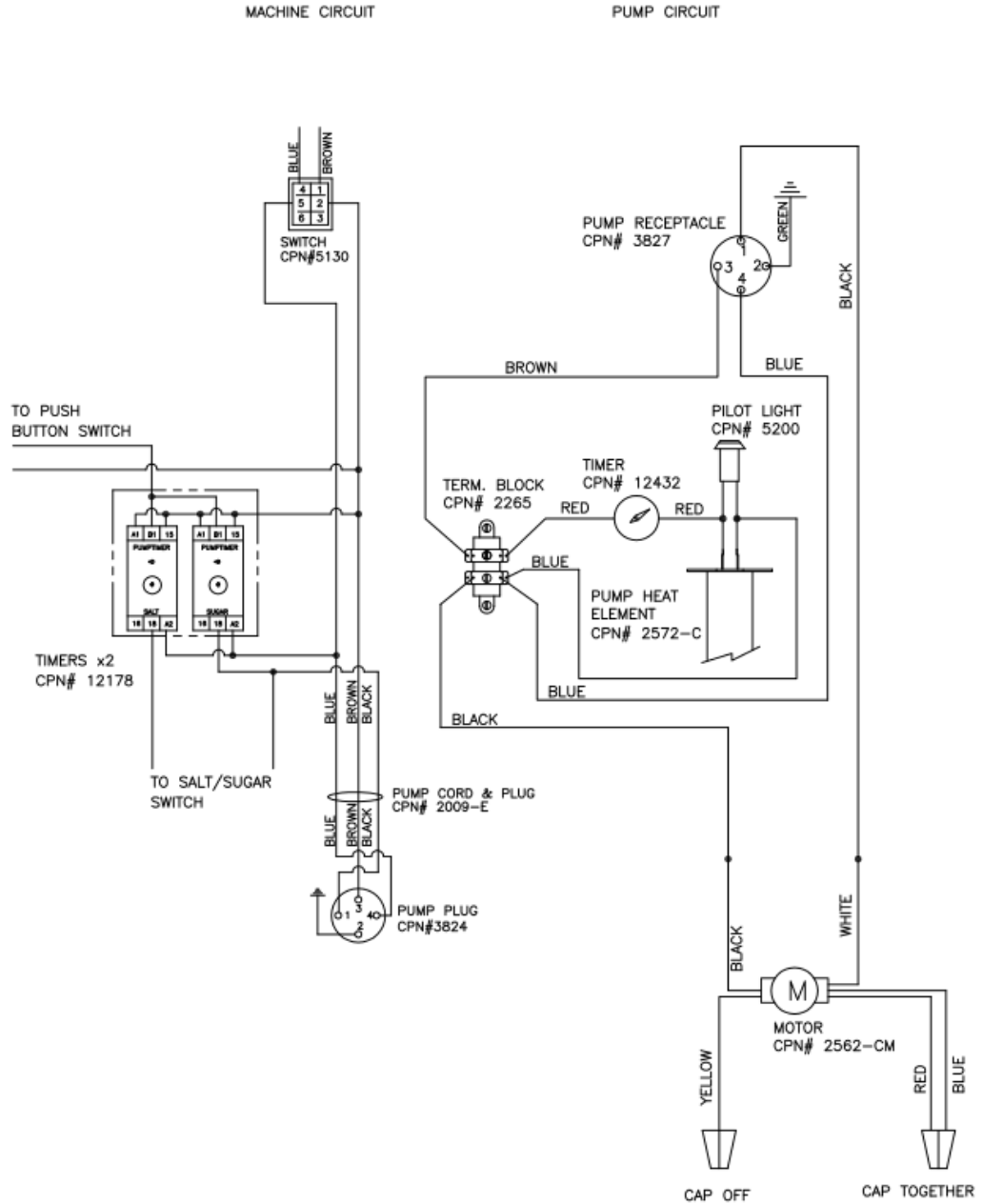

C.CRETORS AND COMPANY
 170 MITTEL DRIVE
 WOOD DALE, ILLINOIS, 60191
 PHONE(847)616-6900, (800)228-1885, FAX (847)616-6970
 WEB SITE: <http://www.cretors.com> Email: postmaster@cretors.com

THIS PAGE INTENTIONALLY BLANK



176 MITTEL DRIVE, WOOD DALE, IL 60191

7900 Bag-N-Box Pump Manual

Models 7900RCA-___, 7900LA-___, 7900GMA-
7900-RCE-___, 7900LE-___, 7900GME

120 Volt
Single Phase, 60 Cycle

100/120 Volt
Single Phase, 50/60 Cycle

230 Volt
Single Phase, 50 Cycle

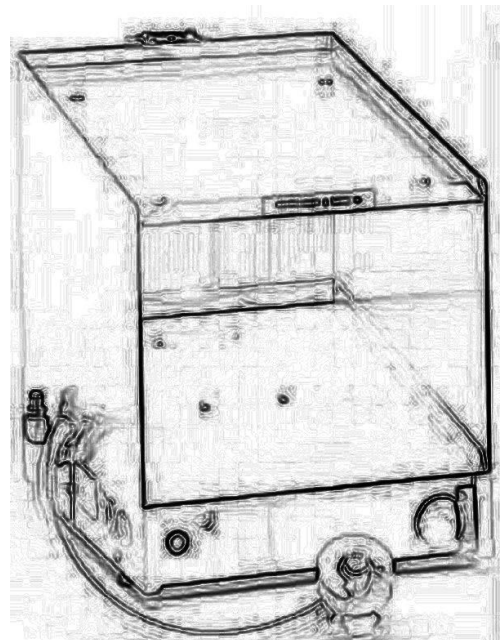

READ and UNDERSTAND these servicing, and safety instructions before servicing this popcorn machine

Part Number Configuration: 7900 Bag-N-Box Oil Pump

7900 RC A - S X

Model

7900 – 7900 Bag-N-Box Pump

Control

RC - Remote Control

L – Salt/Sugar (LOG Control)

GM - Remote Control (Gold Medal Plug)

Voltage

60 Hz. (North America)

A - 120/1/60

50 Hz

E - 230/1/50

Japan

F - 100/1/50

Oil Connection

S - Side Oil Line Connections (Standard)

F - Front / Rear Oil Line Connections

Options

X - No Custom Features

C - Custom Features

H - Heated Tubes

EH - 30" Heated Tubes

Z - Other

I. SAFETY ALERT SYMBOL

The symbol shown below is used to call your attention to instructions concerning your personal safety and the safety of others. Watch for this symbol. It points out important safety precautions and procedures. It means **ATTENTION! Become Alert! Your personal safety is at risk!** Read the message that follows and be alert to the risk of personal injury or death.



II. SAFETY FIRST



The information in this manual is essential for safe installation and service of your Cretors machine. The manual must be read and understood before installing, or maintaining equipment, or equivalent training must be provided.



"The employer must instruct each employee in the recognition and avoidance of unsafe conditions, regulations applicable to his work environment to control and eliminate any hazards or other exposure to illness or injury".
Ref.: 29 CFR 1926.20 (b)(4)(a)(2)



It is understood that safety rules within individual companies vary. If a conflict exists between the safety procedures contained in this manual and the rules of a using company, the more stringent rule should take precedence.

III. INTRODUCTION

This manual is filled with time-saving and money-saving information regarding your Cretors machine. There is nothing, however, more important than the safety aids and warnings that are found throughout this document. The Safety Alert Symbol is used to identify topics of primary safety concern wherever they appear. A separate section has been included which deals exclusively with operation and accident prevention.

If, after reviewing this manual, anything is unclear or technical problems are encountered, contact the distributor from whom you purchased your machine. For assistance and if there are any additional questions, feel free to contact our Customer Service Department at the address and/or phone number listed on the last page of this manual. Always have the model and serial number of your machine available to assist in obtaining the correct information.

IV. SPECIFICATIONS

A. ELECTRICAL SPECIFICATIONS:

Electrical configurations:

120 Volt, Single Phase, 60 Hz

100/120Volt, Single Phase, 50/60 Hz

230 Volt, Single Phase, 50 Hz.

B. SIZE SPECIFICATIONS:

MODEL 7900	7900 AUTOMATIC OIL PUMP MODEL
Capacity:	(2) 35 lb. boxes of oil.
Electrical:	120 volt, 60 cycle, single phase, 250 watts, 2.1 amps.
Dimensions:	16-1/2" H x 18-1/4" D x 14-3/4" W
Net Weight:	30 lbs.
Shipping Weight:	39 lbs.

MODEL 7900	7900 AUTOMATIC OIL PUMP MODEL
Capacity:	(2) 35 lb. boxes of oil.
Electrical:	230 volt, 50 cycle, single phase, 250 watts, 1.1 amps.
Dimensions:	16-1/2" H x 18-1/4" D x 14-3/4" W
Net Weight:	30 lbs.
Shipping Weight:	39 lbs.



7900 Bag-In-Box Oil Pump



Part Number	Voltage	Wattage	NEMA Plug
**7900X(X)X-X	120v (60Hz); 230v (50Hz)	250	5-15

Shipping Weight: 35 lbs/ Shipping Dimensions: 22in x 18in x 19in
Metric Shipping Weight: 16 kg/ Shipping Dimensions: 56cm x 44cm x 49cm
**Actual dimensions available in technical drawing below*
***Actual part number dependant on machine features*

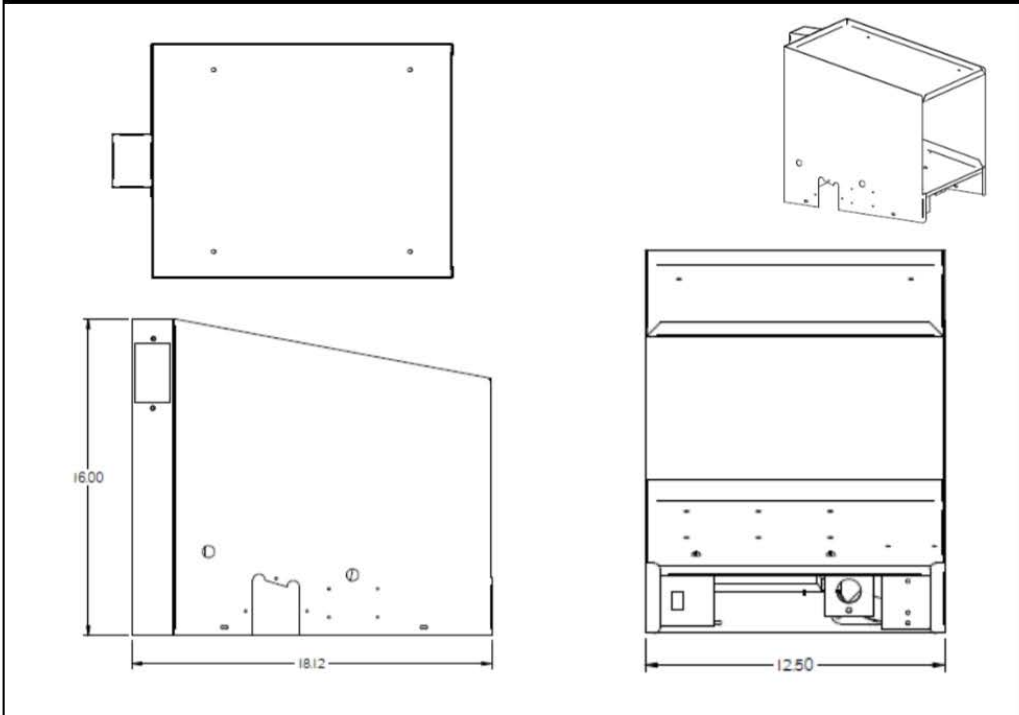

V. PURPOSE OF MANUAL

This instruction manual is intended to familiarize owners with the servicing and safety procedures associated with your Cretors machine.

This manual should be kept available to maintenance personnel.

VI. INSTALLATION INSTRUCTIONS

A. Location

Choose a location for your Cretors machine that maximizes the ease of operation and maintenance procedures. Be sure to check your local building and fire codes for location restrictions.

B. Power Supply

1. The 7900 Oil Pump is provided with either 120 volt components, which requires a 120 volt circuit for proper operation or 230V components. Check the nameplate to determine the required power supply.



Connect your popcorn machine and oil pump only to the correct power source. Failure to do so may result in personal injury or death and may damage your popper.

2. C. Cretors and Company recommends dedicated circuits for the 7900 Model Cretors Oil Pump. The 7900 Model Cretors Oil Pump requires a dedicated circuit to avoid a voltage drop in the supply wiring. Check your local electrical codes regarding fuse or circuit breaker requirements.



Make certain your machine is properly grounded. Failure to do so may result in damage to your equipment or present a shock hazard.

C. Connecting Oil Pump to the Power Supply

1. Make certain that the power supply circuit breakers are in the off position.



Perform work only on de-energized circuits. Failure to do so may result in damage to your equipment or present a shock hazard.

2. Make certain all switches on the popcorn machine are in the off position before plugging in your 7900 Model Cretors Oil Pump.
3. Plug your popcorn machine and oil pump into the correct type of outlet, turn on the circuit breaker and then turn on the machine switches. If the motor groans, the receptacle in the wall may have been improperly wired. Contact an electrician.

D. Pump Installation

1. Make certain the pump switch on the control panel is in the off position.
2. Receiving a 7900 pump as a replacement for 7700 or earlier models.
 - a. The units equipped with wood bases, remove the (2) screws on back flange of oil pail tray (P/N 1349) and remove tray. This tray is not needed for 7900 model.
 - b. Replace existing plastic hose (#1223) (7" on Diplomat, 19" on President) with 20" or 24" plastic hose respectively. The existing hose clamps (#1609) and socket (#5216) are still used. If existing hose length was shortened so the socket (#5216) does not have sufficient length to connect to the plug (#5217) on the pump, replace the entire length - 110" (for Merchant and Profiteer).



Use proper lifting techniques when removing the pump assembly to avoid injury to back.

3. The 7900 model weighs approximately 30 lbs., so use proper lifting techniques and slide pump into cabinet. Allow at least 3" from the front edge of pump to the back side of door. This will ensure that the door, when closed, will not interfere with the properly connected bag connector.
4. Connect hose (#1223) simply by pushing socket (#5216) into plug (#5217) and make sure that it has snapped into place. Test engagement by pulling up on the hose near connection, fittings will not disengage.
5. Connect pump cord and plug to pump receptacle located on the top or on the back of the model 7900 pump.
6. While using proper lifting techniques, load one box into bottom tray and one on top. Following the instructions on the box itself, connect the bag connector to the Bag-N-Box nozzle. You are now ready to adjust the pump as outlined in Pump Adjustment.



Make sure that the popper heat switch is in the off position during all pump adjustments. Failure to do so may result in serious burns.



WARNING! If either shelf is not occupied by the Bag-N-Box oil, use caution around these surfaces as they will be hot! Failure to do so may result in serious burns.

E. Pump Adjustment

1. Make sure that the pump power switch and the auxiliary switch located on the popper are on.
2. Check the output of the pump by placing the kettle in the dumped position and hold the oil measuring cup under the oil delivery tube. With the pedestal mounted units (i.e. Giant/President), disconnect the oil tube from the kettle and dispense the oil into the measuring cup.



WARNING! Never hold the oil measuring cup under the oil delivery tube if the kettle is in the up position. **The kettle maybe hot!** Failure to do so may result in serious burns.

3. Press the delivery button or One Pop button and wait for the pump to cycle. Dispose of the oil, and cycle the pump again.
4. After three cycles, the amount of oil delivered will be consistent. Check this amount with the measuring cup.
5. If the amount of oil is not correct, it may be adjusted. For a Salt/Sugar machine, the timer is located in the popper. To adjust the pump:
 - a. Turn off the pump switch.
 - b. To set the amount of oil being delivered:
 - i) Remove the snap out plug on the front side of the bottom cover to expose the timer.
 - ii) Check to make sure the timer has good contact by pushing down lightly onto the timer base, making certain not to push any of the switches.
 - iii) Switches 1 through 10 are each assigned a certain amount of seconds of run time. Each successive switch doubles the run time for the switch before it. The amount of run time is written at the top, along the Open/Off line (i.e. 1,2,4,8, etc.)
 - iv) The switch must be in the Up position along the Open/Off line for the run time to apply. For example, to make the pump run for three seconds, the timer would have the switch corresponding to 1 on the Open/Off line up along with the switch corresponding to 2 on the Open/Off line.

To turn the dip switches ON the dip switch needs to be pressed down to the number side opposite of the open side. Open is off.

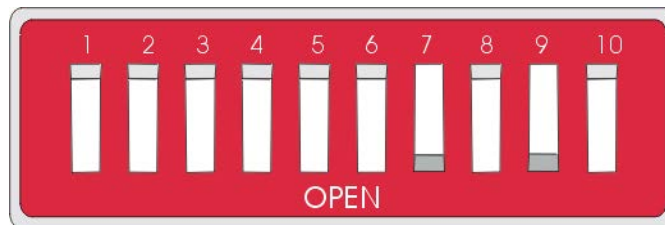

- Switch #1 = 1 seconds
- #2 = 2 seconds
- #3 = 4 seconds
- #4 = 8 seconds
- #5 = 16 seconds

Example: If you turn #3 and #4 on, the time delay will be 12 seconds.

<u>Machine</u>	<u>Recommended Amount of Oil</u>	<u>Set Timer to Number of Seconds (Your results may vary.)</u>
PT14	4.5 oz.	3 seconds

MR16	5.5 oz.	4 seconds
DI20	6.5 oz.	5 seconds
PR20	6.5 oz.	5 seconds
EG20	6.5 oz.	5 seconds
DI32	10.5 oz.	9 seconds
PR32	10.5 oz.	9 seconds
EG32	10.5 oz.	9 seconds
GG32	10.5 oz.	9 seconds
EG48	16 oz.	12 seconds
EG60	20 oz.	16 seconds

- c. Turn on the pump switch and re-check the oil output using steps 1-5 in the Pump Adjustment Section.
- d. Install snap out plug.

F. Bag-N-Box Connector

1. Prepare the box for use by breaking the perforated opening on the box and bending back the corrugated tab. Reach inside and grasp the bag spout. Place the ring of the spout into the box slot and lock it into place with the corrugated tab.
 - a. Place the Bag-N-Box in the appropriate shelves. Next remove the travel cap from the spout. The travel cap prevents the dirt and dust from coming in contact with the internal slider for sanitary hook-up.
 - b. Snap the locking plate over the bag spout. The tapered probe on the connector is then pushed into the bag spout and it locks into place. This bi-directional locking action does two things. One, it eliminates any possibility of accidental disconnect, giving the user a “fool proof” positive connection and two, it opens the channel allowing product to follow.
 - c. When the Bag-N-Box container is empty, disengage the connector by snapping the connector probe into the out position and remove it from the bag spout. This disconnects and reseals the bag. All product contact surfaces are protected ensuring a sanitary situation.
 - d. Repeat steps a-c to properly re-connect Bag-N-Box to the pump.

NOTE: Prior to each attachment of the Bag-N-Box connector, ensure that the probe has not been contaminated. If this has occurred, clean the connector as described in the **Sanitation Instructions**.

VIII. OPERATING INSTRUCTIONS



Do not attempt to operate your Cretors popcorn machine or oil pump until you have read and understood this manual. Failure to do so may result in serious injury or death.



Do not attempt to operate your Cretors popcorn machine or oil pump unless the installation instructions have been strictly adhered to. Failure to do so may result in serious injury or death.



Operate your oil pump only if it is in good sanitary condition (See **SANITATION INSTRUCTIONS**). Failure to do so may result in illness to your customers.



Always turn the kettle heat switch off when not popping corn. Failure to do so will cause oil to stain the kettle, possibly resulting in an unsanitary condition. It may also cause a “flash” fire if oil is added to a kettle left unattended with the heat on, resulting in serious burns or death.

A. Operate only after “Installation Instructions” in the Service Manual have been followed.

B. To operate your Cretors 7900 oil pump:

1. Turn on the pump switch, located on the popper, to the on position.
2. Pre-heat the popping oil until liquid, if necessary.
3. Push the oil pump or the One-Pop button to dispense oil. If too much or too little oil is being dispensed, see “Pump Adjustment” in the Service Manual.
4. Exchange boxes by disconnecting bag connector from bottom and connecting to top.
5. Follow the recommended sanitation procedures.

IX. SANITATION INSTRUCTIONS



Be certain the machine is turned off and power is unplugged before sanitizing this machine unless a specific cleaning procedure requires power to the machine. Failure to do so could result in injury or death.



Do not clean heated surfaces until they have been given sufficient time to cool. Failure to do so may result in serious burns or scalds.

The 7900 pump is designed as a closed system and should remain aseptic.

If you believe your pump system is contaminated, then you will need to clean the system.

The pump is cleaned using the following steps:

1. Remove the Bag-N-Box connector.
2. Place the end of the oil tube into hot soapy water in a pail.
3. Cycle pump sufficiently to flush system. Be sure to have a container to catch the water at the discharge tube near the kettle.
4. Move the oil tube to clean hot water and cycle pump to flush hot soapy water from the system.
5. **IMPORTANT:** When system is clean, you must then cycle the system with oil to prevent any damage to the pump. **Never leave the pump wet with water only.** Mineral oil may be used.

To Clean Bag-N-Box Connector:

1. Remove from tubing.
2. Remove probe body from clamp by spreading clamp body tabs and sliding probe body out.
3. Remove probe spout adapter from probe body by unscrewing stem from probe body.
4. Remove seal body and spring from stem and nut assembly by unsnapping seal body from stem.
5. Clean all parts in accordance to NSF and local requirements (hot, soapy water, and rinse). Do not use petroleum base cleaning agents or abrasive cleaners. Damage to sealing surfaces may occur and jeopardize the sanitary integrity of the connector.
6. Inspect the three "O" rings for damage or imbedded particles. Replace as required.
7. Reassemble by reversing steps 1-4.

Sanitation of your popcorn machine and oil pump is imperative for production of an appetizing product. Failure to follow proper sanitation procedures for food contact surfaces or usage of contaminated ingredients (salt, oil, seasonings) could result in poor product quality and may cause illness to your customers.

Your Cretors oil pump is National Sanitation Foundation (NSF) listed, and can be easily cleaned to assure a high quality product. Use pure ingredients, always emphasize machine sanitation, and follow the sanitation procedures outlined in this manual to protect the welfare of your customers.

X. TROUBLE SHOOTING



In the case of improper operation, only a qualified person should perform the following diagnostic checks, and, if necessary, corresponding adjustments and repairs. Many of the following procedures may present an electrical shock hazard and can cause serious injury or death.



Perform work only on de-energized circuits. Failure to do so may lead to electrical shock resulting in personal injury or death.

PROBLEM	POSSIBLE CAUSE	ACTION
Nothing works.	Is the pump plugged in?	Plug in.
	Is the switch turned on?	Turn on the switch on the popper.
Pump not heating.	Check element.	Use an ammeter to diagnose. Replace if bad.
Motor hums, but will not turn.	Debris in pump.	Clean out pump.
	The motor burned out, because it cannot turn.	Replace motor. Check for the correct alignment between the motor and the pump.
Pump runs all the time.	Timer set incorrectly.	Reset. (See Pump Adjustment)
	Bad timer.	Replace timer.
Motor runs, but does not dispense oil.	Check for oil in the box.	Exchange.
	Pump sucking plastic bag, not oil by the nozzle.	Move connector.
	Is the line clogged?	Assure lines do not have hardened oil blocking the line and heated lines are warm
Amount of oil delivered is not consistent.	Check oil tubing for leakage and for restrictions.	Fix or replace clamps on tubing.
	Bag-N-box connector improperly installed.	Re-install connector.
	Oil is not in liquid state.	Wait till oil is liquid.

Do not attempt to operate pump if the Bag-N-Box is in the upright position.

This manual is filled with time-saving and money-saving information regarding your Cretors Bag-N-Box Oil Pump. There is nothing, however, more important than the safety aids and warnings found throughout this document.

If you have any questions, contact your local distributor and if there are any additional questions, feel free to contact the Customer Service Department at C. Cretors and Company.

Additional copies of this manual can be obtained from C. Cretors and Company at the address listed below. Please provide model and serial number when requesting additional copies of this manual. There will be a nominal charge for additional copies.

Cretors guarantees this machine to be free of defects in parts, materials and workmanship for two years. Please take this time to fill out the factory registration card and return it to Cretors to activate your warranty. If you have any questions concerning the Cretors' warranty, please contact your local distributor or the Customer Service Department at C. Cretors and Company.



C. CRETORS AND COMPANY

176 MITTEL DRIVE

WOOD DALE, IL 60191

PHONE (773) 588-1690, (800) 228-1885, FAX (847) 616-6970

WEB SITE: <http://www.cretors.com> Email: postmaster@cretors.com

7900 - PUMP - 120V
 BEGINNING SERIAL: 99080000

DOC: 79003001

7900-A-3.0-A
 9/99

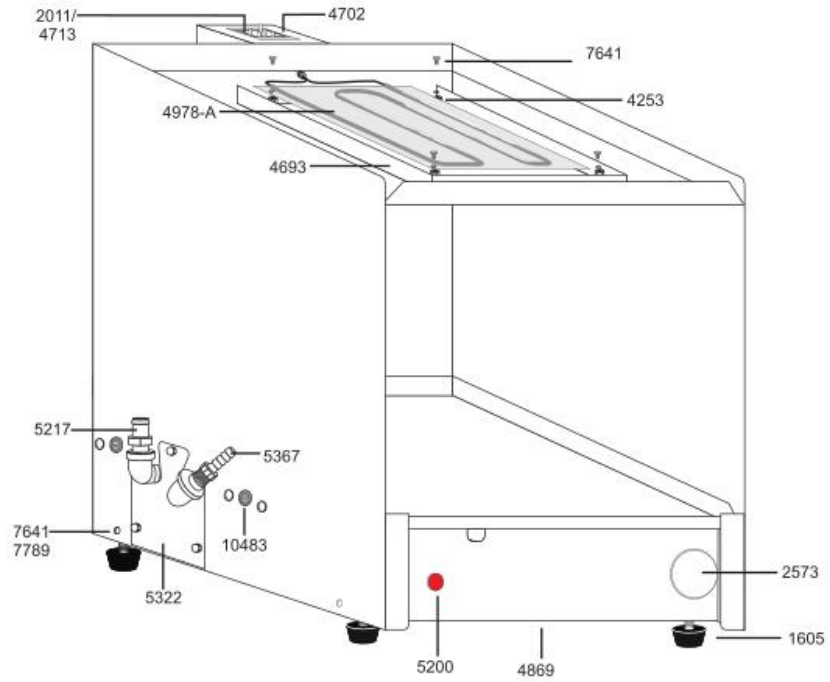

5970-F HEATER FRONT ASSY

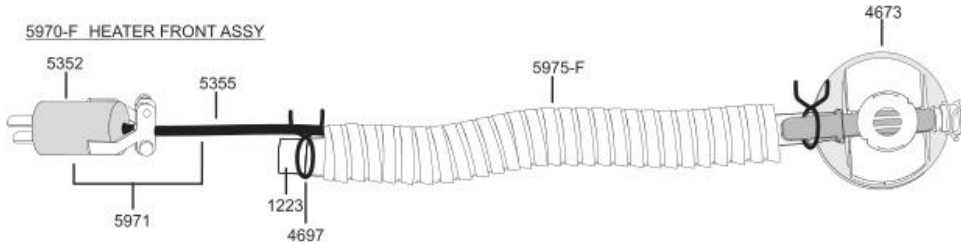

5970-R REAR HEATER ASSY

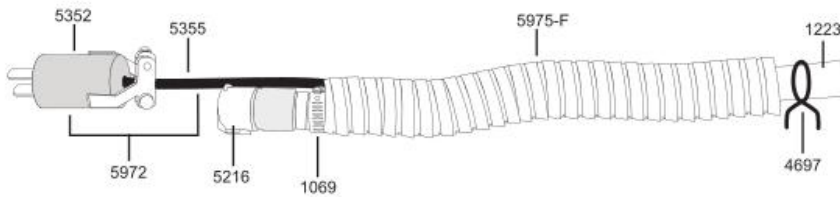

C. CRETORS AND COMPANY

7900 - PUMP - 120V

BEGINNING SERIAL: 99080000

DOC: 79003001

7900-A-3.0-A
9/99

1605 RUBBERFOOT W/ HARDWARE
 2011 RECEPTACLE
 2573 HOLECOVER CRING
 4253 8-32X1/2 SPACER HEX
 4693 ELEMENT CORNER
 4702 TOP END WIRE BOX
 4713 RECEPTACLE-GOLD METAL
 4869 BOTTOM COVER
 4978 HEAT PAD
 5200 INDICATOR LIGHT
 5217 PLUG-ON CHARGE CONNECT
 5322 COVER PLATES SIDE CHARGE
 5367 HOLE BAR
 5970-F HEATED TUBE ASSEMBLY FRONT (Parts Also Sold Separately)
 5352 PLUG
 5355 HEATER-ROPE 18"
 5971 HEATER FRONT ASSEMBLY
 5975-F SLEEVE-316 STAINLESS STEEL- FRONT
 1223 TUBING-MANGANESE- CLEAR PERFECT
 5970-R HEAT TUBE ASSEMBLY REAR (Parts Also Sold Separately)
 1069 HOSE CLAMP
 5352 PLUG
 5355 HEATER-ROPE 18"
 5972 REAR HEATER ASSEMBLY
 5975-F SLEEVE-316 STAINLESS STEEL- REAR
 1223 TUBING-MANGANESE- CLEAR PERFECT
 7641 8-32X1/4 STAINLESS HEAD
 7789 #8 STAR WASHER
 10483 RECEPTACLE ASSY

C. CRETORS AND COMPANY

7904 WARMER - 120V
BEGINNING SERIAL: 98074678

DOC: 79043001

7904-A-3.1-A
9/98

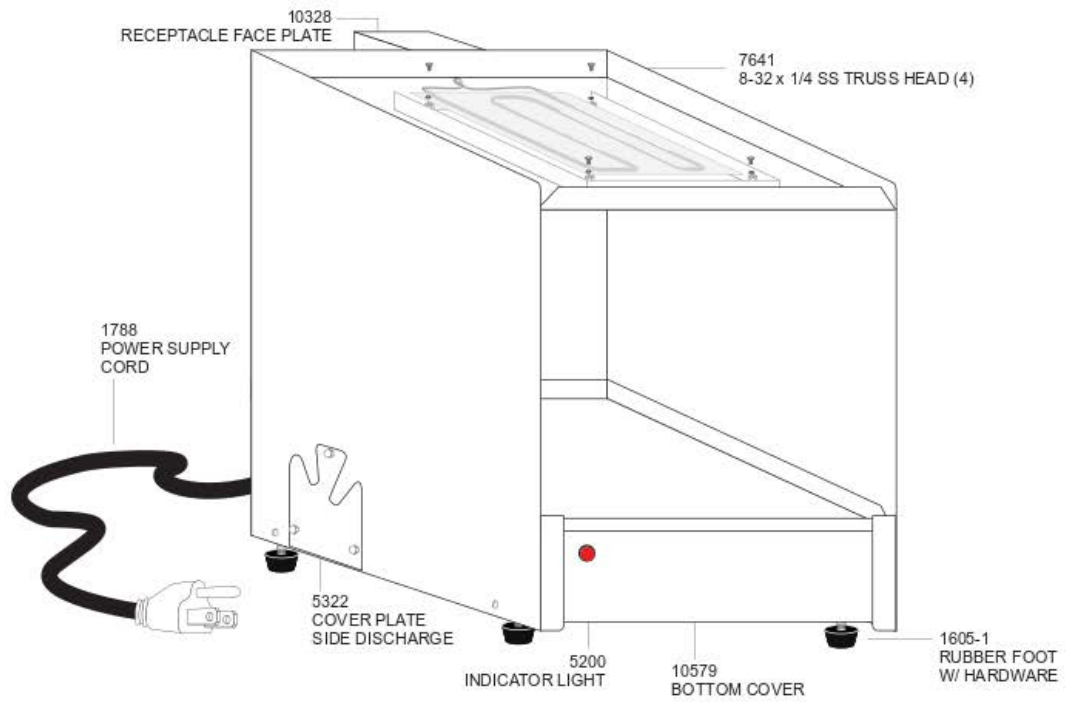

C. CRETORS AND COMPANY

7904 WARMER - 100-120V
BEGINNING SERIAL: 06104678

DOC: 79043002

7904-A-3.1-B
10/06

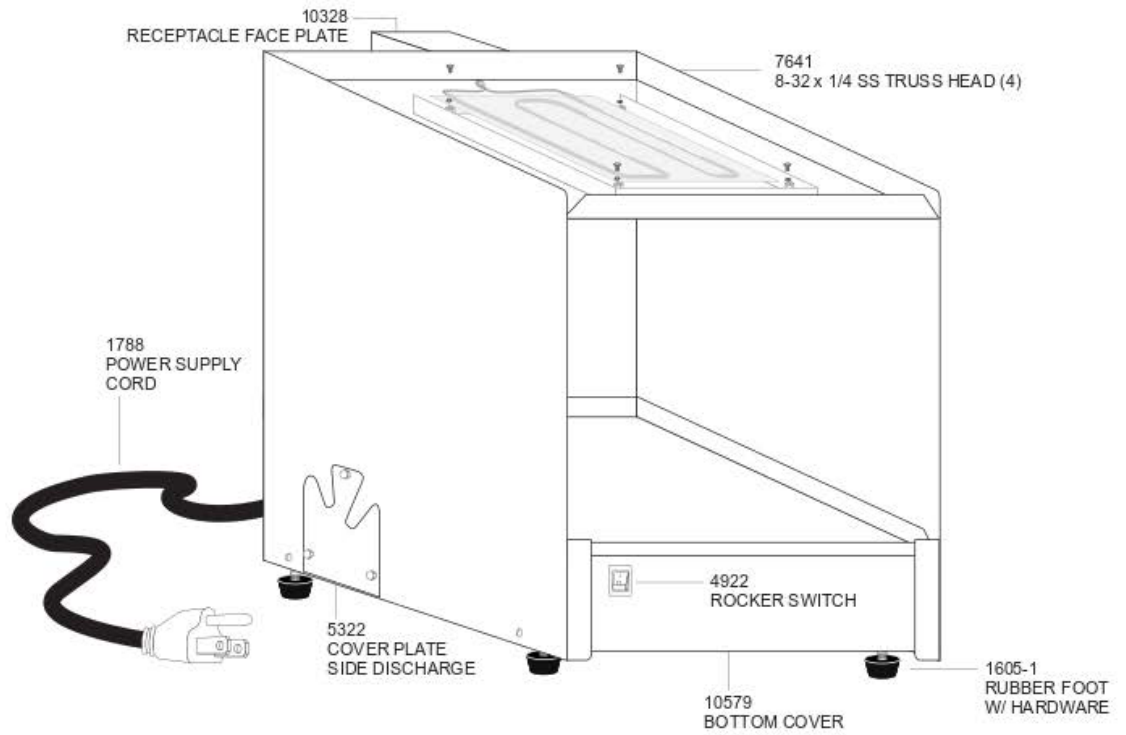

C. CRETORS AND COMPANY

7900 BAG-N-BOX PUMP 120V/230V-HEATED

DOC: 79003004

7900-A-3.1-B

BOTTOM VIEW
BEGINNING SERIAL: 0504

12/18

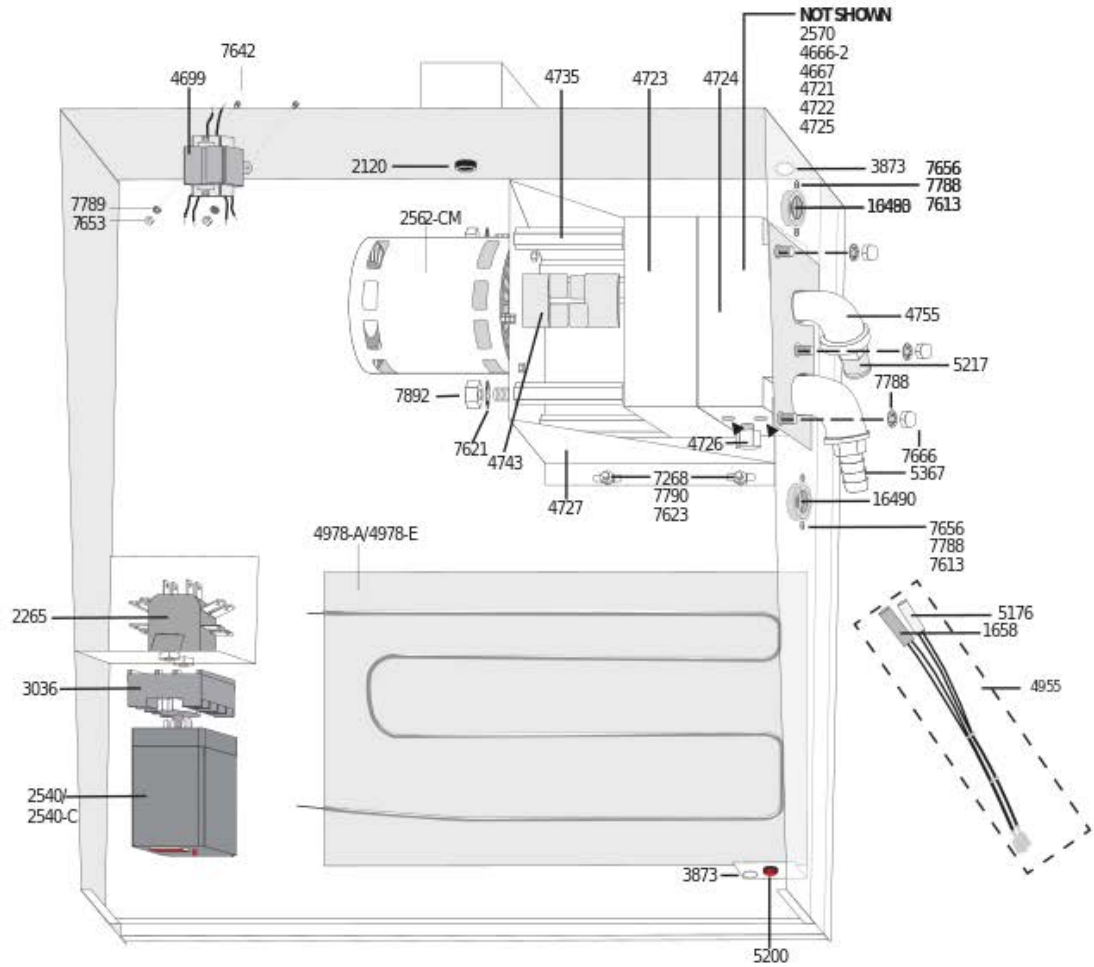

4750 - DUAL CDC PUMP COMPONENTS ASSEMBLED



C. CRETORS AND COMPANY

7900 BAG-N-BOX PUMP 120V - HEATED

DOC: 79003004

7900-A-3.1-B
12/18

BOTTOM VIEW

BEGINNING SERIAL: 0504

1658	HEATER - TUBULAR	
2120	BUSHING - HEYCO	
2265	TERMINAL BLOCK 2-PIN	
2540-C	TIMER PLUG-IN - 120V	
3036	RELAY BAS E - 8 PIN	
3873	HOLE COVER 5/8	
4699	TRANSFORMER 40VA - 120/208/240 CLAS	S 2 - 240 V OUTPUT
4723	PUMP BODY W/ SEAL	
4724	VALVE BODY	
4726	STOP PLUG & PIN	
4727	BRACKET	
4735	SPACER	
4734	MOTOR (8D262)	
2562-CM	COUPLING	
4755	ELBOW - 90 DEGREE	
4750	CDC PUMP COMPONENTS	
4978-A/4978-E	HEAT PAD-120V	
5200	INDICATOR LIGHT	
5217	PLUG-QUICK DISCONNECT	
5176	THERMOSTAT - TYPE J	
5367	HOSE BARB	
7268	10-32 x 1/2 SLTD TR HD	
7613	6-32 x 5/16 x 7/64 HEX NUT	
7621	1/4" INTERNAL TOOTH LOCKWASHER	
7623	10-32 HEX NUT	
7642	8-32 X 3/8 SS TRUSS HEAD	
7653	8-32 HEX NUT	
7656	6-32 x 3/8 BINDING HEAD	
7666	6-32 CAP NUT	
7788	#6 LOCKWASHER	
7789	#8 STAR LOCKWASHER	
7790	#10 STAR LOCKWASHER	
7892	1/4-20" x 11/64" HEAVY JAM NUT	
16490	RECEPTACLE ASSEMBLY	

NOT SHOWN

2570	PUMP IDLER GEAR (SHORT)
4666-2	SHUTTLE
4667	SPRING
4721	"O" RING
4722	SEAL
4725	GEAR & SHAFT
4721	O RING

C. CRETORS AND COMPANY

176 MITTEL DRIVE

WOOD DALE, IL 60191

PHONE: (847)616-6900, (800)228-1885, FAX: (847)616-6971

WEB SITE: <http://www.cretors.com> Email: postmaster@cretors.com

7900 BAG-N-BOX PUMP 240V - HEATED
 BOTTOM VIEW
 BEGINNING SERIAL 0504XXXX

DOC: 79003006

BIB-E-3.1-A
 03/05

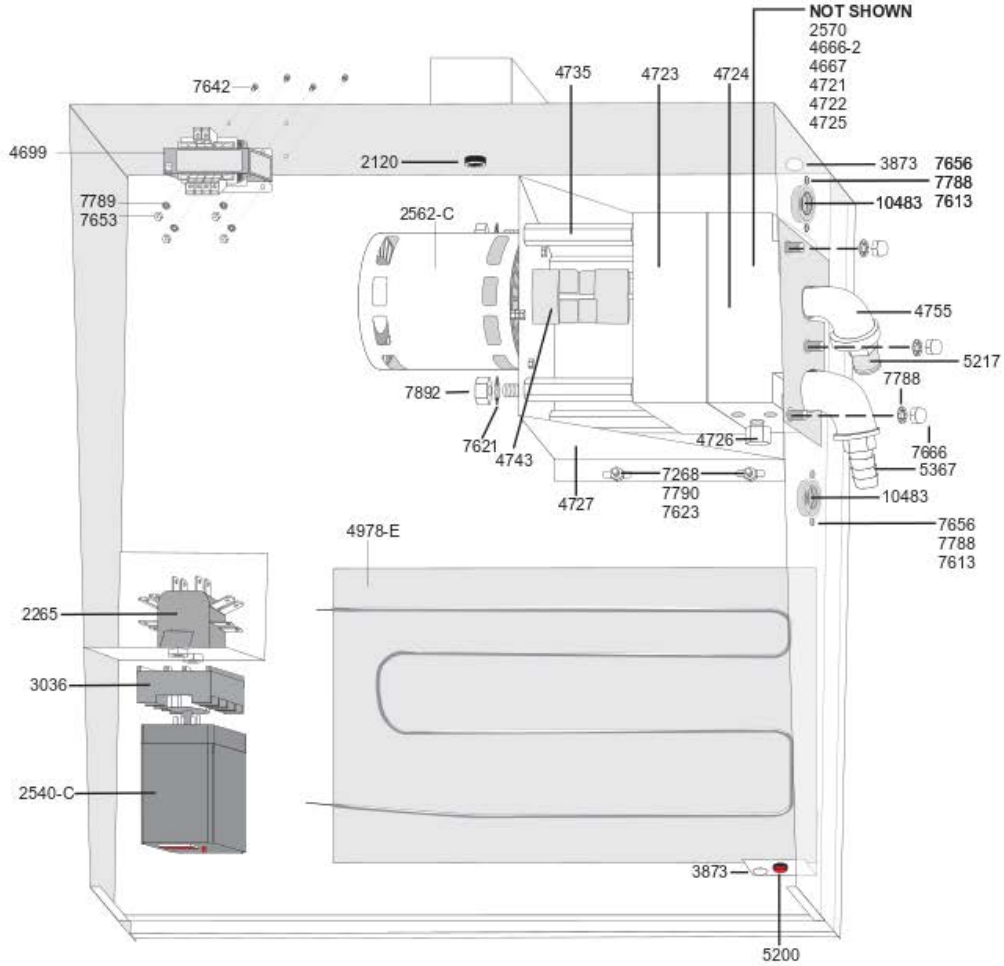

4750-E CDC PUMP COMPONENTS ASSEMBLED

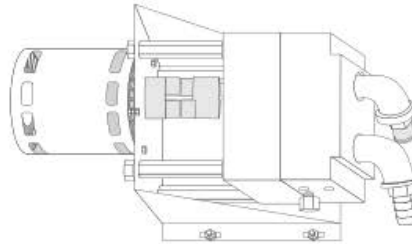

C. CRETORS AND COMPANY

7900 BAG-N-BOX PUMP 240V - HEATED

DOC: 79003006

BIB-E-3-
03

BOTTOM VIEW

BEGINNING SERIAL 0504XXXX

2120	BUSHING - HEYCO
2265	TERMINAL BLOCK 2-PIN
2540-C	TIMER PLUG-IN - 230V
2562-C	MOTOR
3036	RELAY BASE - 8 PIN
3873	HOLE COVER 5/8
4699	TRANSFORMER-40W
4723	PUMP BODY W/ SEAL
4724	VALVE BODY
4726	STOP PLUG & PIN
4727	BRACKET
4735	SPACER
4743	COUPLING
4755	ELBOW - 90 DEGREE
4750-E	CDC PUMP COMPONENTS
4978-E	HEAT PAD - 240V
5200	INDICATOR LIGHT
5217	PLUG-QUICK DISCONNECT
5367	HOSE BARB
7613	6-32 x 5/16 x 7/64 HEX NUT
7621	1/4" INTERNAL TOOTH LOCKWASHER
7623	10-32 HEX NUT
7642	8-32 X 3/8 SS TRUSS HEAD
7653	8-32 HEX NUT
7268	10-32 x 1/2 SLTD TR HD
7656	6-32 x 3/8 BINDING HEAD
7666	6-32 CAP NUT
7788	#6 LOCKWASHER
7789	#8 STAR LOCKWASHER
7790	#10 STAR LOCKWASHER
7892	1/4-20" x 11/64" HEAVY JAM NUT
10483	RECEPTACLE ASSEMBLY

NOT SHOWN

2570	PUMP IDLER GEAR (SHORT)
4666-2	SHUTTLE
4667	SPRING
4722	SEAL
4725	GEAR & SHAFT
4721	"O" RING
4722	SEAL

7900 - PUMP - 120V / 230V
 BEGINNING SERIAL: 10050000

DOC: 79003008

7900-A/E-3.1-B
 05/2010

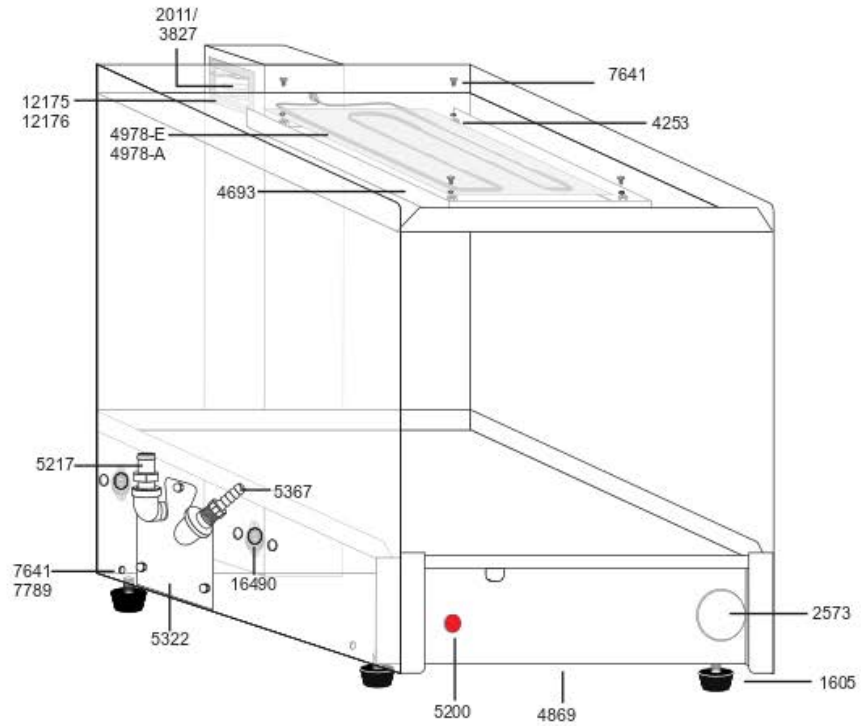

16489-F HEATER FRONT ASSY

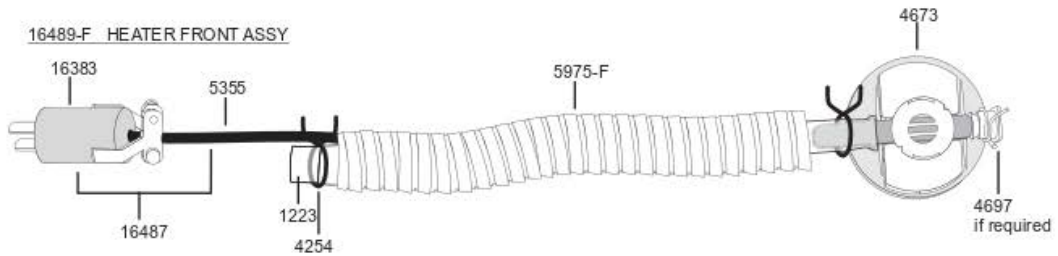

16489-R REAR HEATER ASSY

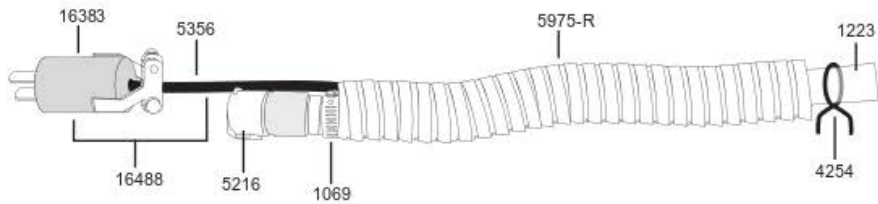

C. CRETORS AND COMPANY

7900 - PUMP - 120V / 230V

BEGINNING SERIAL: 10050000

DOC: 79003008

7900-A/E-3.1-B
05/2010

1605	RUBBER FOOT W/ HARDWARE
2011	RECEPTACLE-120v
2573	HOLE COVER "O" RING
3827	RECEPTACLE-230v
4253	8-32 x 1/2 SPACER HEX
4254	CLAMP-HOSE-SELF TIGHTENING
4693	ELEMENT COVER
4697	HOSE CLAMP-SELF TIGHTENING-1/2
4713	RECEPTACLE-GOLD METAL
4869	BOTTOM COVER
4978-A	HEAT PAD-120V
4978-E	HEAT PAD-230V
5200	INDICATOR LIGHT
5217	PLUG - QUICK DISCONNECT
5322	COVER PLATE SIDE DISCHARGE
5367	HOLE BARB
16489-F	HEATED TUBE ASSEMBLY FRONT (Parts Also Sold Separately)
16483	PLUG
5355	HEATER - ROPE 18"
16487	HEATER FRONT ASSEMBLY
5975-F	SLEEVE - STAINLESS STEEL - FRONT
1223	TUBING - NALGENE - CLEAR PER FOOT
16489-R	HEAT TUBE ASSEMBLY REAR (Parts Also Sold Separately)
1069	HOSE CLAMP
16483	PLUG
5356	HEATER - ROPE 26"
16488	HEATER REAR ASSEMBLY
5975-R	SLEEVE - STAINLESS STEEL - REAR
1223	TUBING - NALGENE - CLEAR PER FOOT
7641	8-32 x 1/4 SS TRUSS HEAD
7789	#8 STAR WASHER
16490	RECEPTACLE ASSY
12175	CONNECTOR PLATE 120V- 7900 PUMP
12176	CONNECTOR PLATE 230V- 7900 PUMP

C. CRETORS AND COMPANY

BAG-N-BOX TOPPER
 WIRING DIAGRAM - 120V 60Hz
 BEGINNING SERIAL No. 1704

DOC: BIBAr2

04/2017

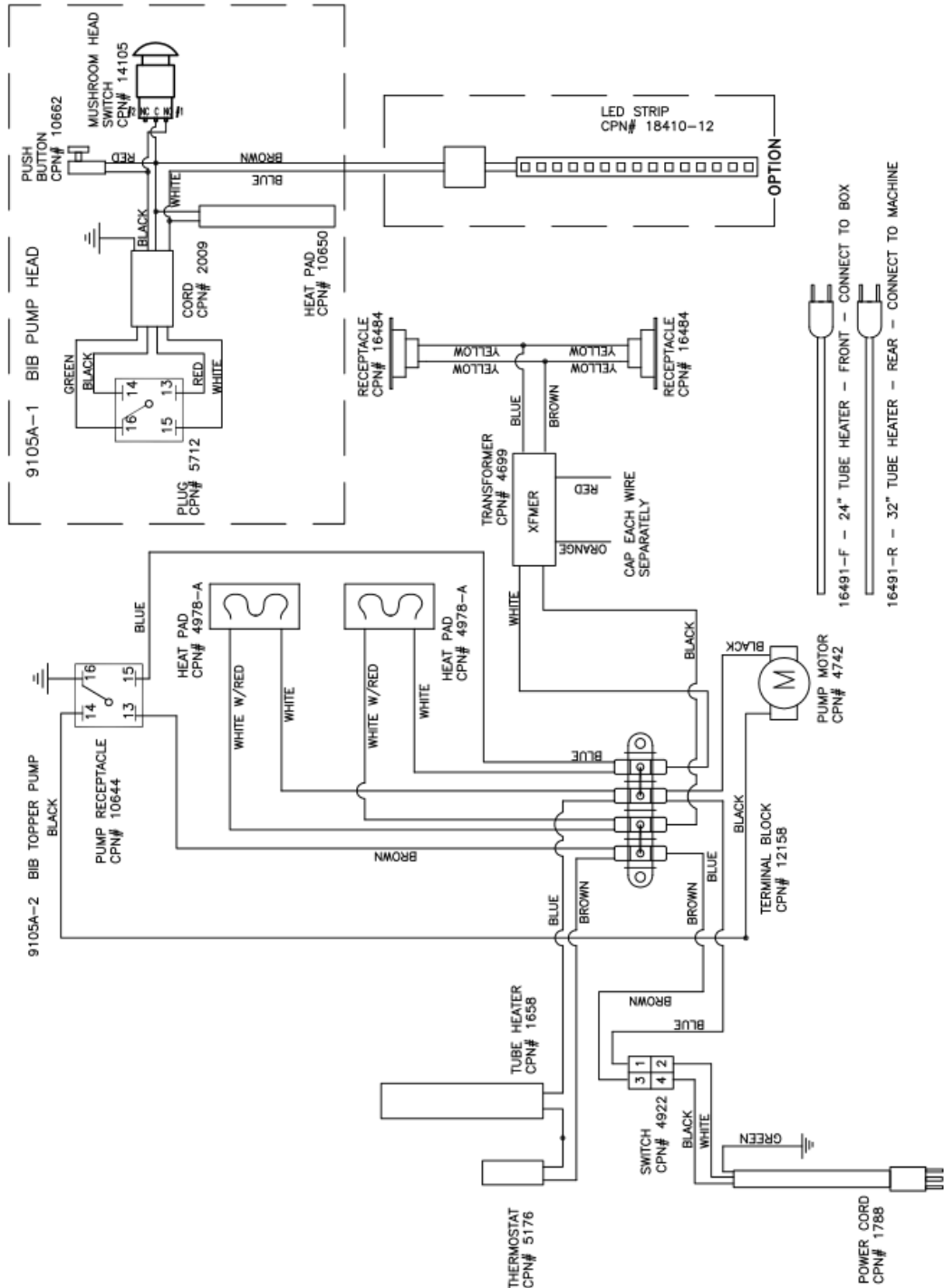

C.CRETORS AND COMPANY
 170 MITTEL DRIVE
 WOOD DALE, ILLINOIS 60191
 PHONE (847)616-6900, (800)228-1885, FAX (847)616-6970
 WEB SITE: <http://www.cretors.com> Email: postmaster@cretors.com

BAG-N-BOX PUMP - HEATED
 WIRING DIAGRAM - 230V 50Hz.
 BEGINING SERIAL No. 1707

LOGIC / SALT SUGAR

DOC: BIBESSr1

07/2017

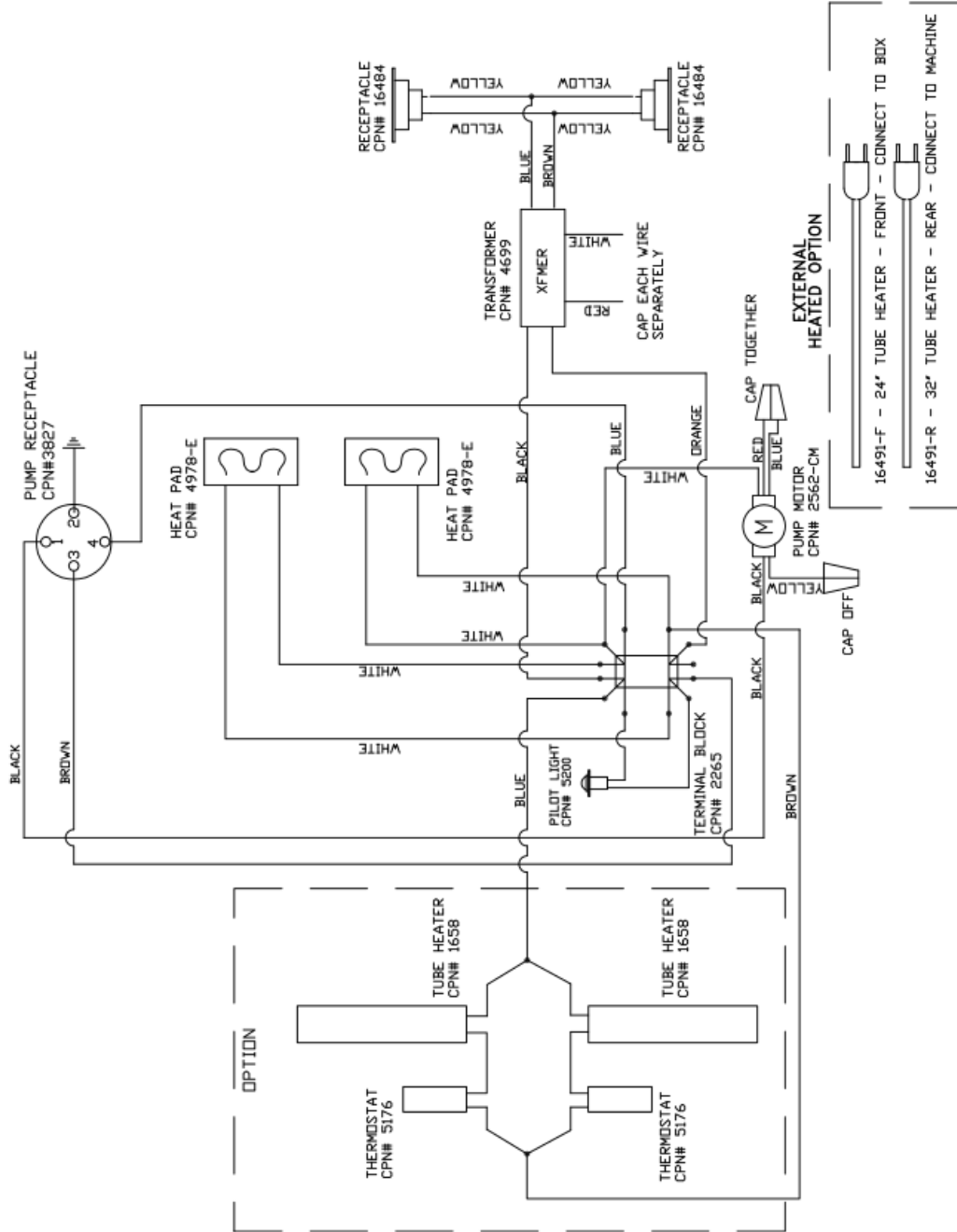

C.CRETORS AND COMPANY
 3243 NORTH CALIFORNIA AVENUE
 CHICAGO, ILLINOIS 60618
 PHONE(773)588-1690, (800)228-1885, FAX (773)588-2171
 WEB SITE: <http://www.cretors.com> Email: postmaster@cretors.com

BAG-N-BOX PUMP - HEATED SALT/SUGAR-LOGIC
 WIRING DIAGRAM - 100/120V 50/60Hz.
 BEGINING SERIAL No. 1701

DOC: BIBASSr2

01/2017

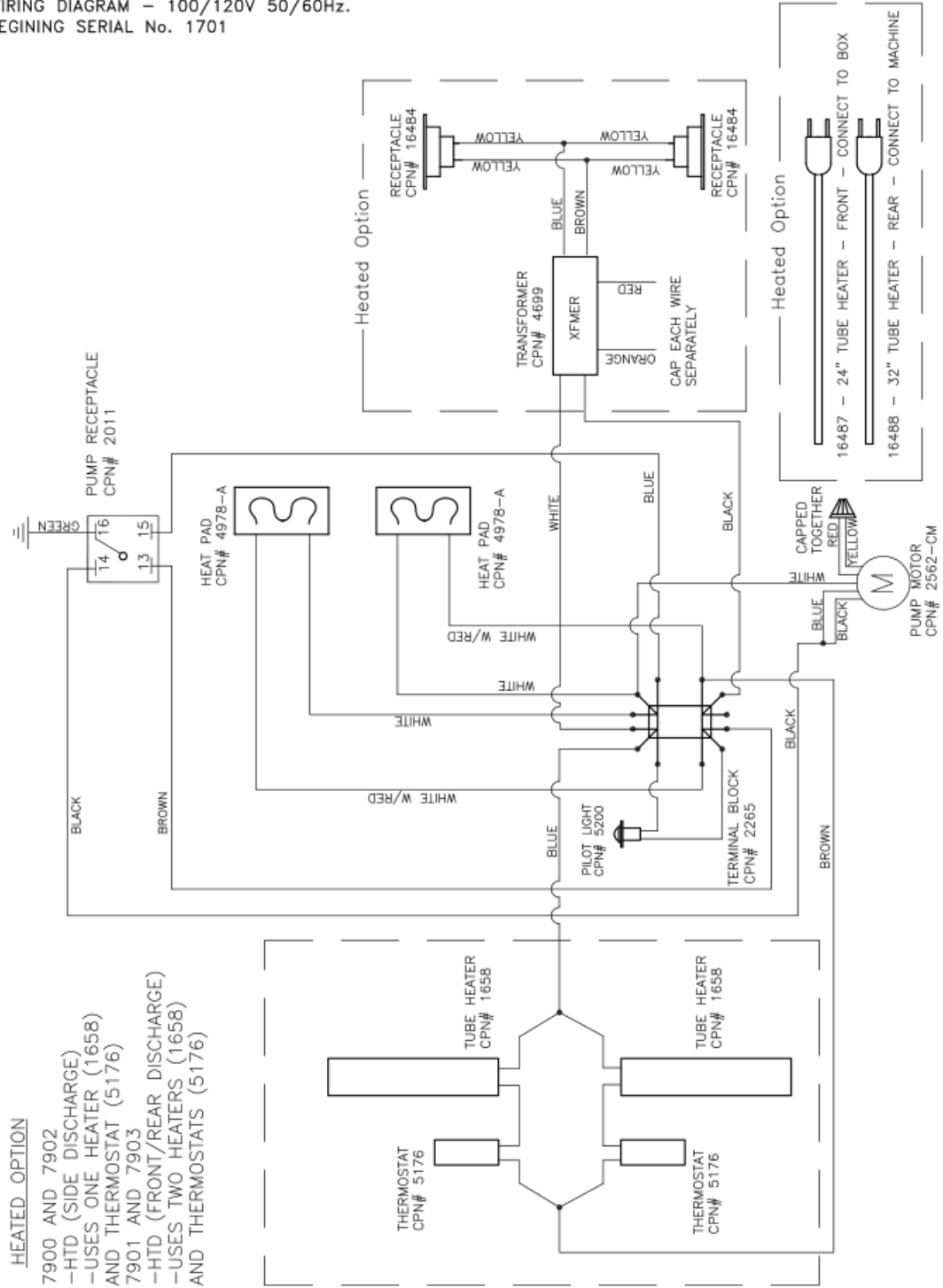

C.CRETORS AND COMPANY
 170 MITTEL DRIVE
 WOOD DALE, ILLINOIS 60191
 PHONE(847)616-6900, (800)228-1885, FAX (847)616-6970
 WEB SITE: <http://www.cretors.com> Email: postmaster@cretors.com

BAG-N-BOX TOPPER / SELF SERVE
 WIRING DIAGRAM - 120V 60Hz
 BEGINING SERIAL No. 1703

DOC: BIBTASFSVr1

03/2017

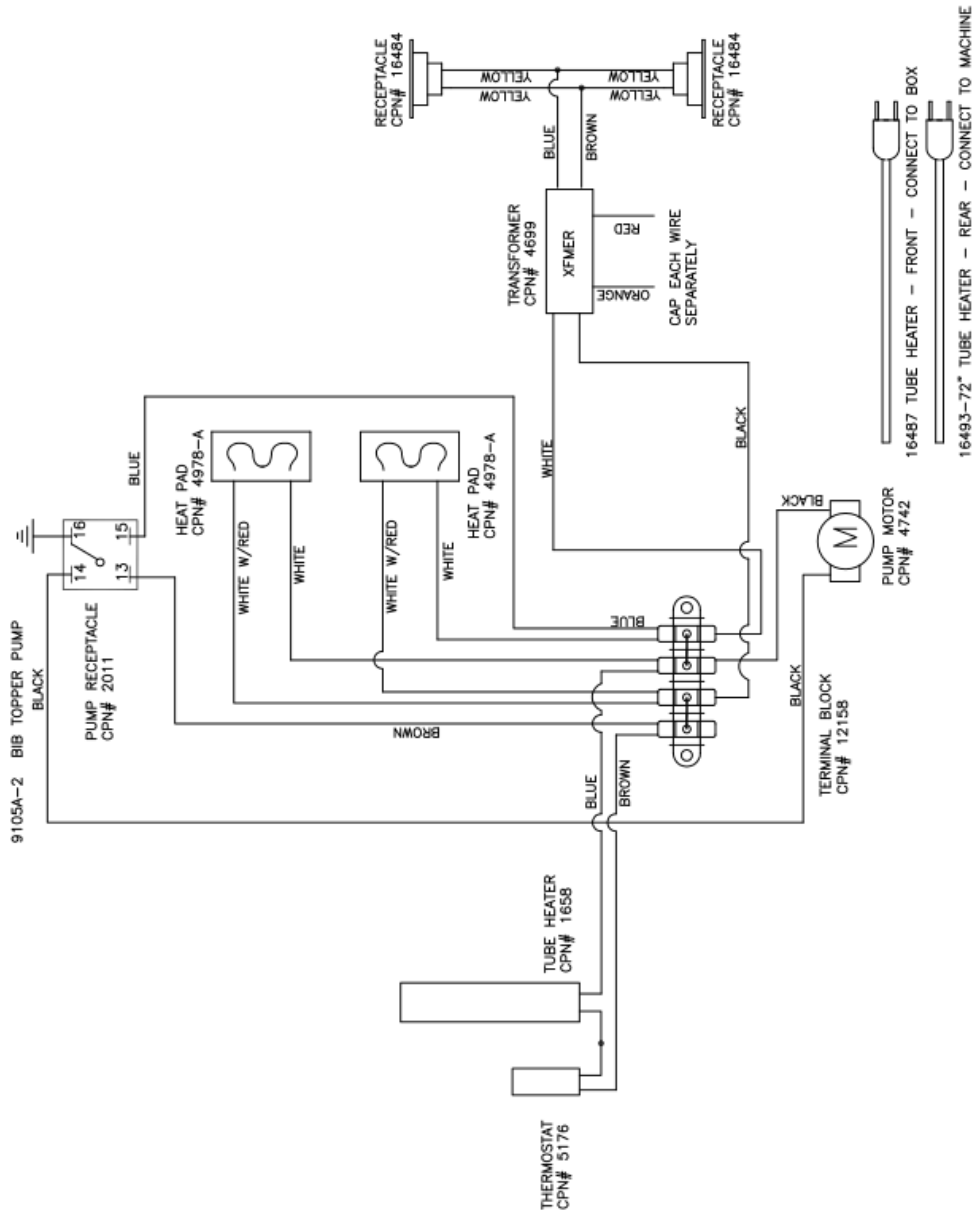

C.CRETORS AND COMPANY
 170 MITTEL DRIVE
 WOOD DALE, ILLINOIS 60191
 PHONE(847)616-6900, (800)228-1885, FAX (847)616-6970
 WEB SITE: <http://www.cretors.com> Email: postmaster@cretors.com

BAG-N-BOX PUMP - 7900/7901/7902/7903 - HTD
 WIRING DIAGRAM - 100-120V 50/60Hz
 BEGINING SERIAL No. 1612

DOC: BIBAr3

12/2016

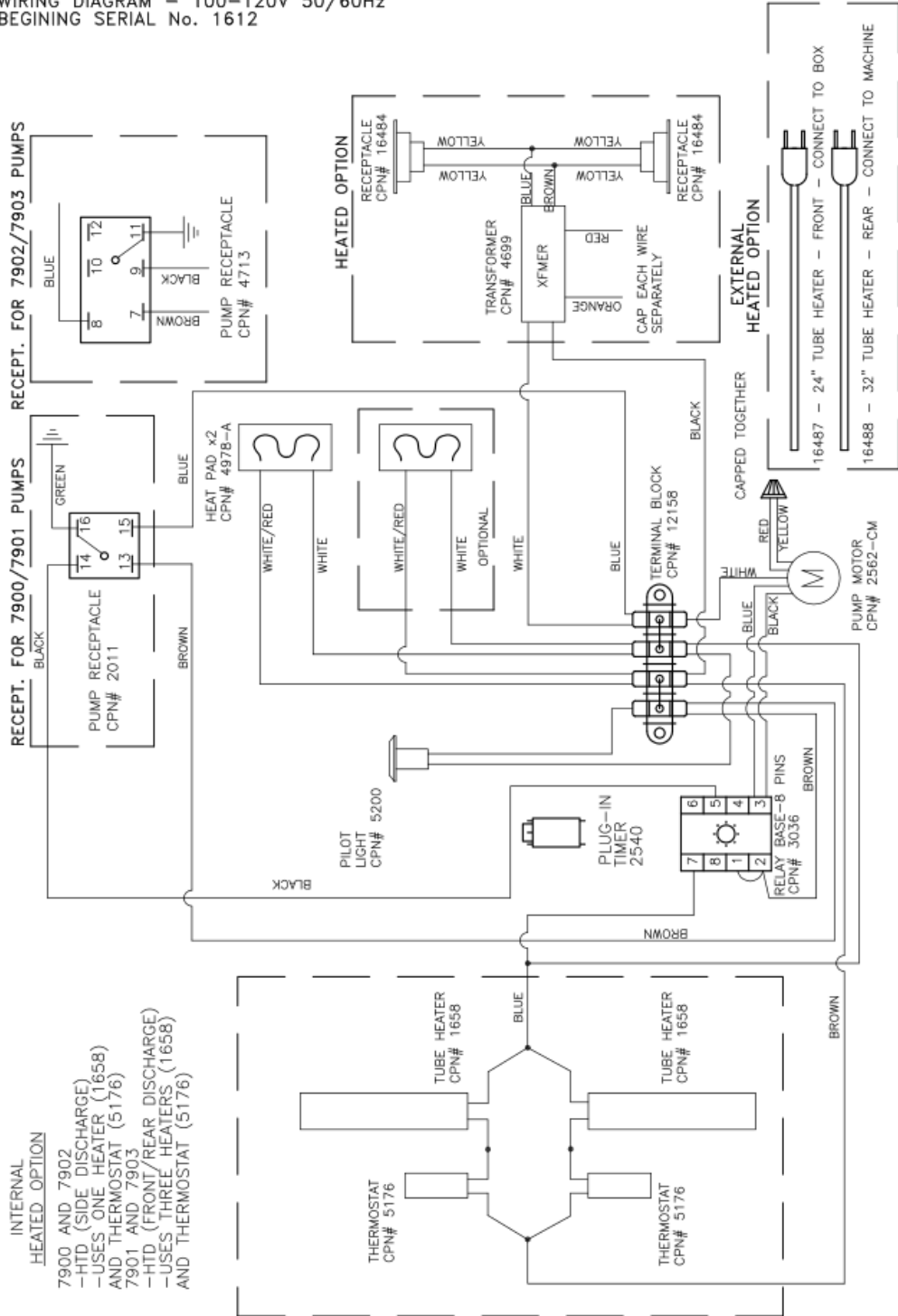

C.CRETORS AND COMPANY
 170 MITTEL DRIVE
 WOOD DALE, ILLINOIS 60191
 PHONE(847)616-6900, (800)228-1885, FAX (847)616-6970
 WEB SITE: <http://www.cretors.com> Email: postmaster@cretors.com

LIMITED TWO YEAR WARRANTY

We warrant to the purchaser of each new CRETORS popcorn machine and related products that we will replace F.O.B. our factory. Any part which proves to be defective in material or workmanship within two years from the date of purchase providing such part is returned to C. Cretors & Company. Transportation charges prepaid. This warranty does not apply to a part damaged by accident, abuse, misapplication or misuse. Nor can we honor any claim for repairs or service unless previously authorized by us.

This warranty gives you specified legal rights and you may have other rights which vary from state to state.

C.CRETORS & CO.
176 Mittel DR
Wood Dale, Illinois 60191-1142

IMPORTANT NOTICE

FACTORY REGISTRATION

IMPORTANT - Please complete and return this card immediately so that we can promptly add your name to our Owner Registration files. By returning this card, you will ensure that the (2) two year warranty covered above is in force. The return of this card ensures our ability to provide you prompt, effective service, and also positively identifies the original owner.

Purchase Date _____ Model _____ Serial # _____

Detach and return bottom section.

FACTORY REGISTRATION CARD

Owner's Name _____ Date _____

Owner's Address _____ Phone # () _____

Owner's City _____ State _____ Zip Code _____

Purchase Date _____ Model _____ Serial # _____

Dealer's Name _____ City & State _____

Reason for Purchase (✓ check as many as applicable):

Home use Commercial use Price Quality Availability Dependability

Size Dealer recommendation Advertising Other _____

C. CRETORS & CO. • 176 MITTEL DR • WOOD DALE, IL 60191-1142



NO POSTAGE
NECESSARY
IF MAILED
IN THE
UNITED STATES



BUSINESS REPLY MAIL
FIRST-CLASS MAIL PERMIT NO. 23000 WOOD DALE, IL

POSTAGE WILL BE PAID BY ADDRESSEE
C. CRETORS AND COMPANY
176 MITTEL DRIVE
WOOD DALE IL 60191-1142

